

LOC		DIST		REVISIONS			
P	LTN	DESCRIPTION	DATE	DWN	APVD		
1		PRELIMINARY	30JUN2011	AL	CW		
2		REVISED PR ECO-14-018993	2APR2015	RG	MC		

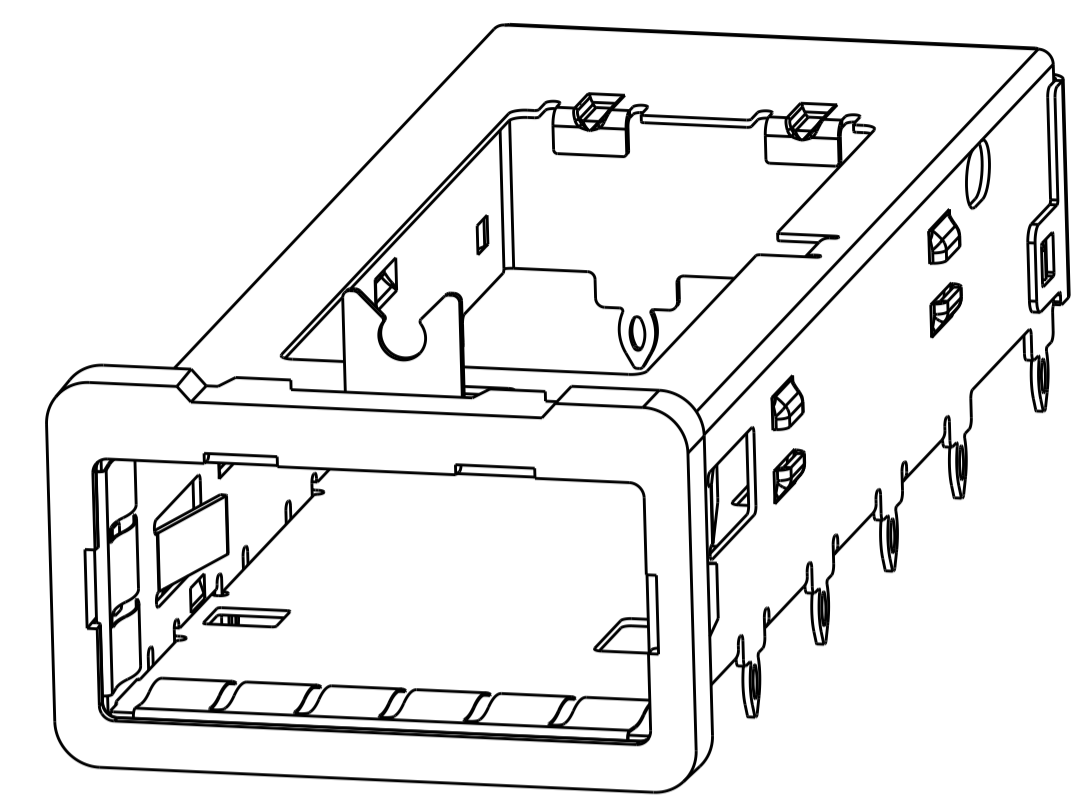

ISOMETRIC VIEW
SCALE 4:1

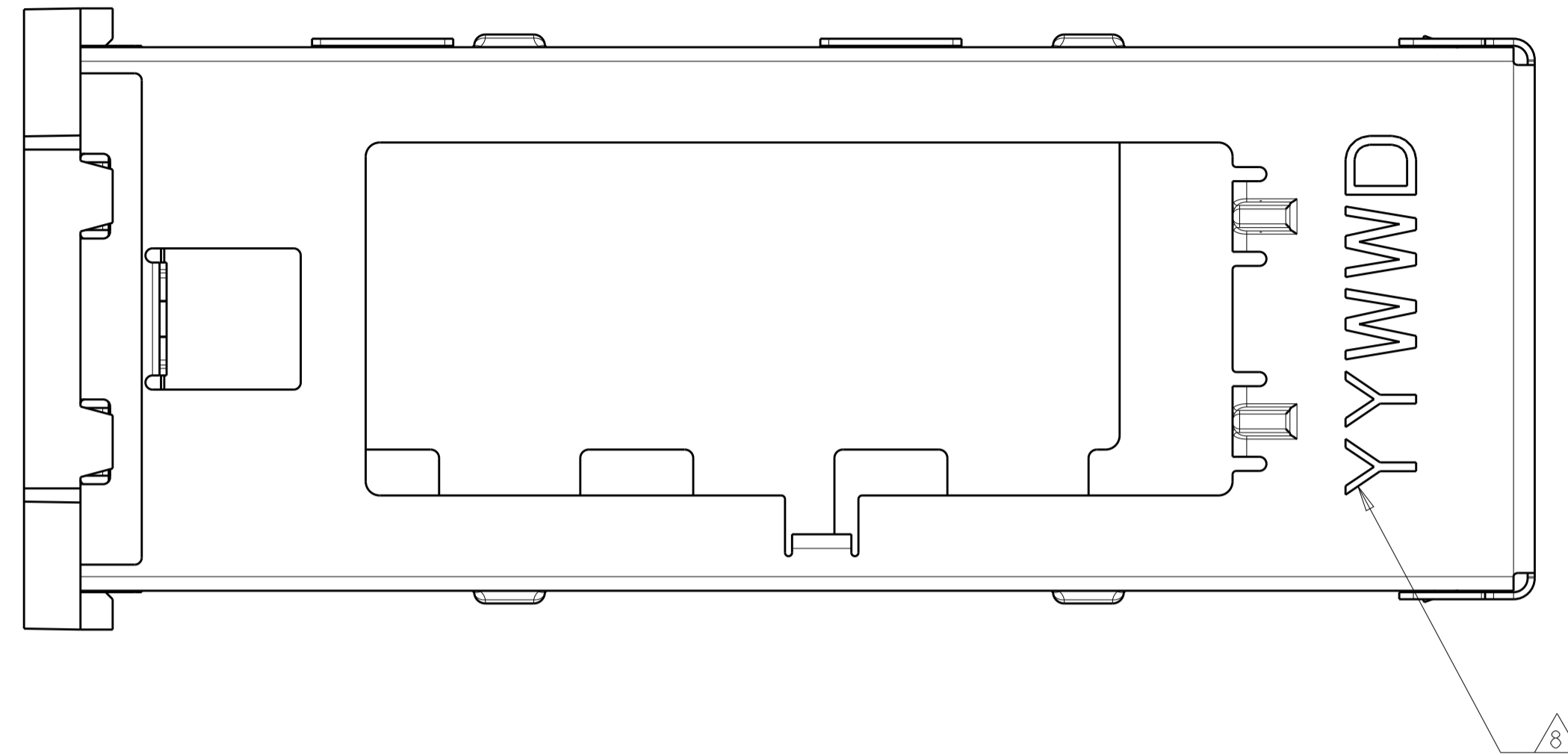

- 1. SURFACE TRACES PERMITTED WITHIN THIS LENGTH EXCEPT WHERE CAGE STANDOFFS, SHOWN IN DETAIL J, CONTACT PC BOARD.
- 2. MINIMUM PITCH DIMENSION.
- 3. MATES WITH QSFP MSA COMPATIBLE TRANSCEIVER.
- 4. REFERENCE APPLICATION SPEC 114-13218 FOR RECOMMENDED DRILL HOLE DIAMETER AND PLATING THICKNESS.
- 5. DATUM AND BASIC DIMENSIONS ESTABLISHED BY CUSTOMERS.
- 6. DIMENSION C IS THE NOMINAL THICKNESS OF CUSTOMER SUPPLIED PC BOARD,
SINGLE SIDED PC BOARD MINIMUM THICKNESS: 1.45
DOUBLE SIDED PC BOARD MINIMUM THICKNESS: 2.7.
- 7. DATUM [-A-] IS TOP SURFACE OF THE HOST BOARD.
- 8. DATE CODE (YYWW) MARKED APPROXIMATELY AS SHOWN.
- 9. CAGE MATERIAL: 0.25 THICK NICKEL SILVER
EMI SPRING MATERIAL: COPPER ALLOY
FRONT FLANGE MATERIAL: ZINC ALLOY.
- 10. EMI SPRING FINISH: 2um MIN TIN
FRONT FLANGE FINISH: 3um MIN THICK TIN OVER 1.27um MIN THICK NICKEL OVER 5.08um MIN THICK COPPER.
- 11. PRODUCT HAS NOT COMPLETED QUALIFICATION TESTING.

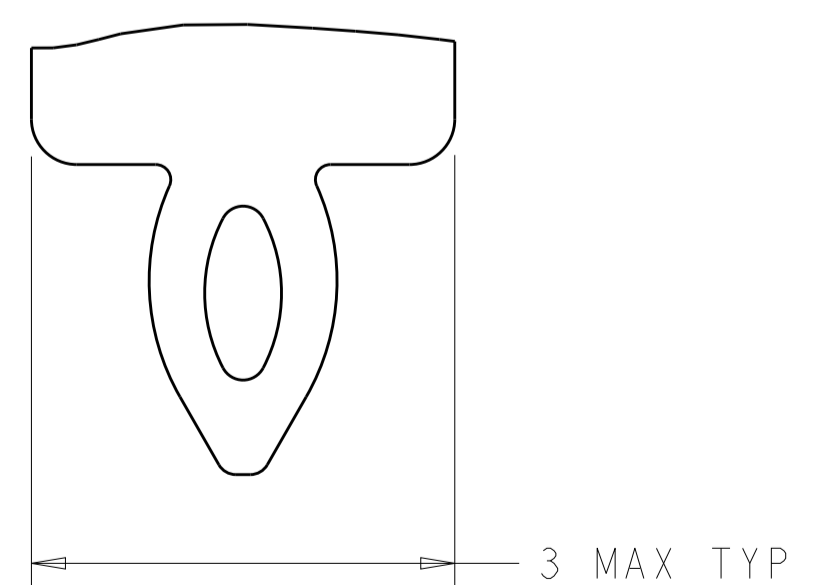
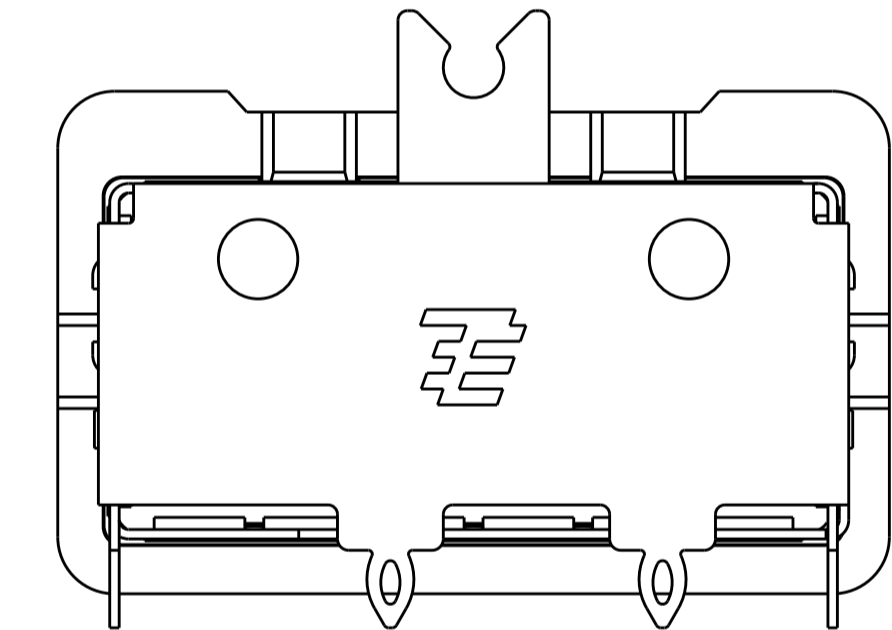
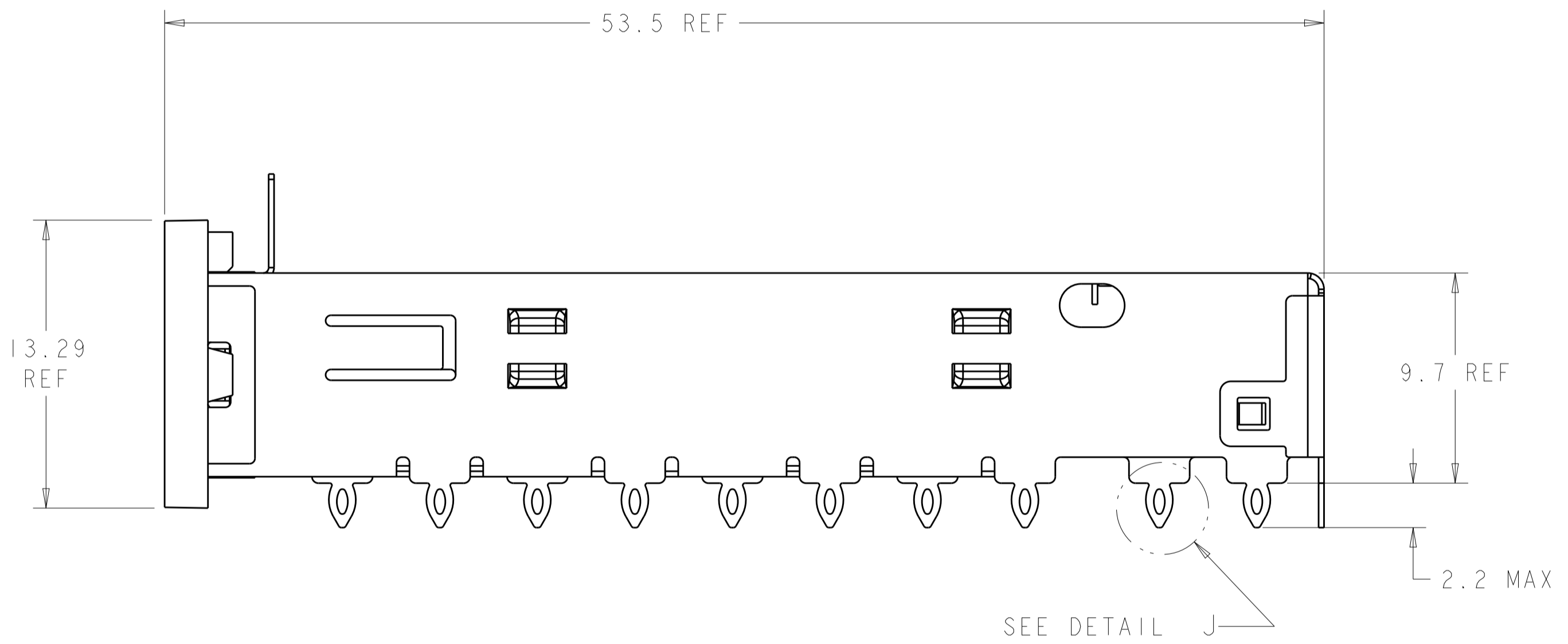
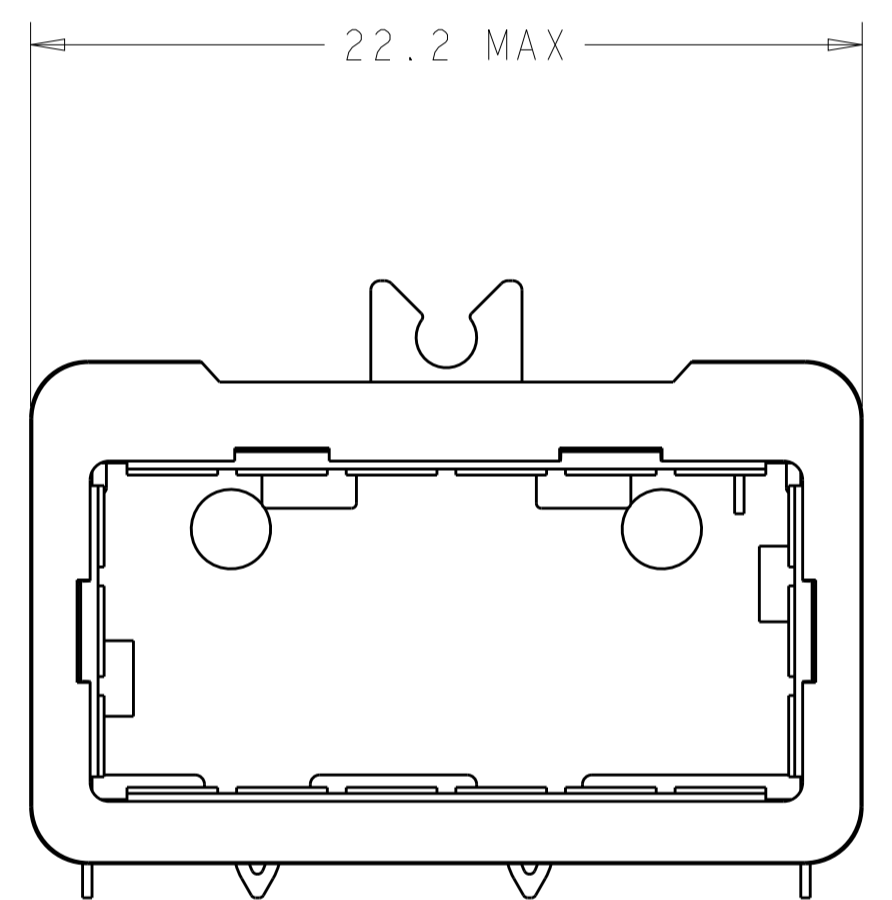

DETAIL J
SCALE 20:1

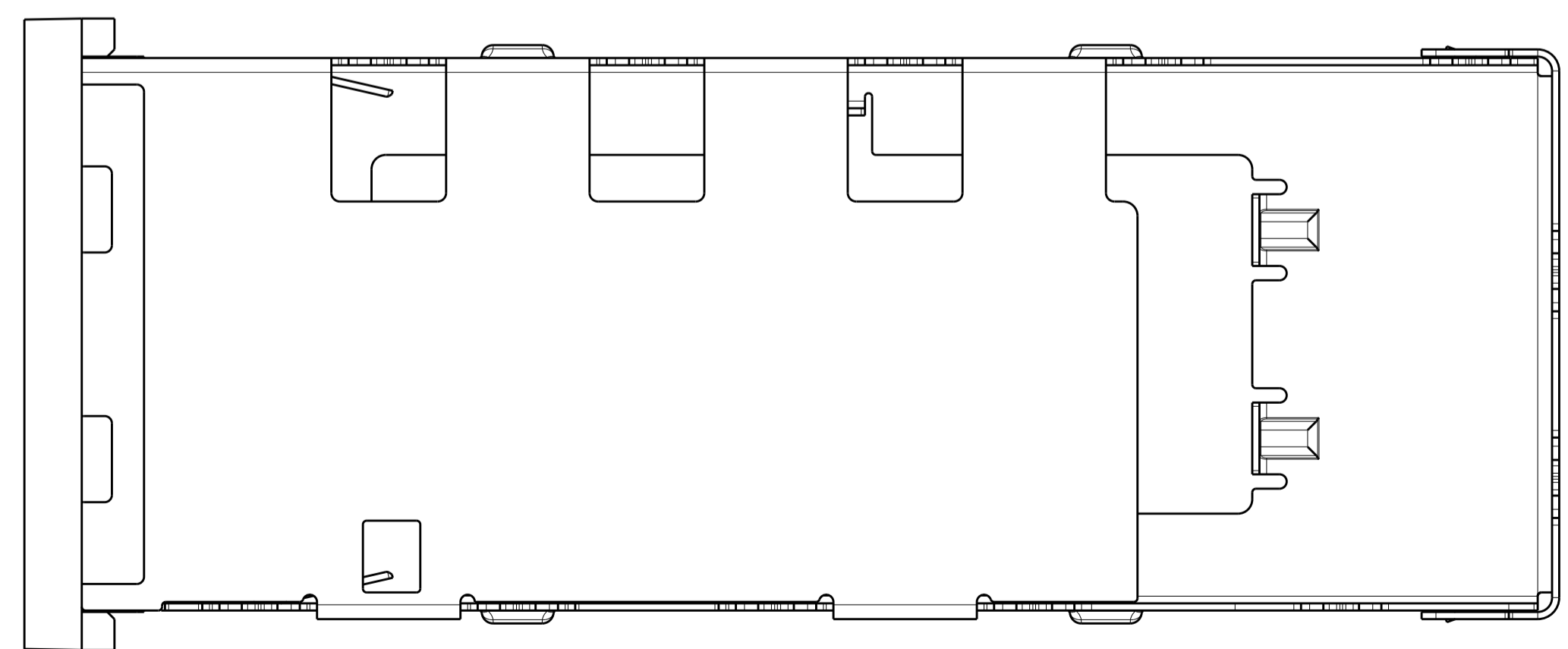

2170111-1
PART NUMBER

THIS DRAWING IS A CONTROLLED DOCUMENT.		DWN: 27JUN2011	STE TE Connectivity	
		CHK: 28JUN2011		
DIMENSIONS:		APVD: 30JUN2011	NAME: CAGE ASSEMBLY, BEHIND BEZEL, W/ LIGHT PIPE BRACKET, QSFP	
TOLERANCES UNLESS OTHERWISE SPECIFIED:		PRODUCT SPEC: 108-2286	SIZE: CAGE CODE DRAWING NO: A100779C=2170111	
mm		APPLICATION SPEC: 114-13218	RESTRICTED TO: -	
0 PLC ±0.5		WEIGHT: -	SCALE: 5:1 SHEET 1 OF 4 REV 2	
1 PLC ±0.13		Customer Drawing		
2 PLC ±0.013				
3 PLC ±0.001				
4 PLC ±0.0001				
ANGLES ±0.001				
FINISH: 9				
FINISH: 10				

LOC	DIST	REV	DATE	BY	APPD
GP	00				

REVISIONS			
REV	DATE	BY	APPD
-	-	-	-
-	-	-	-

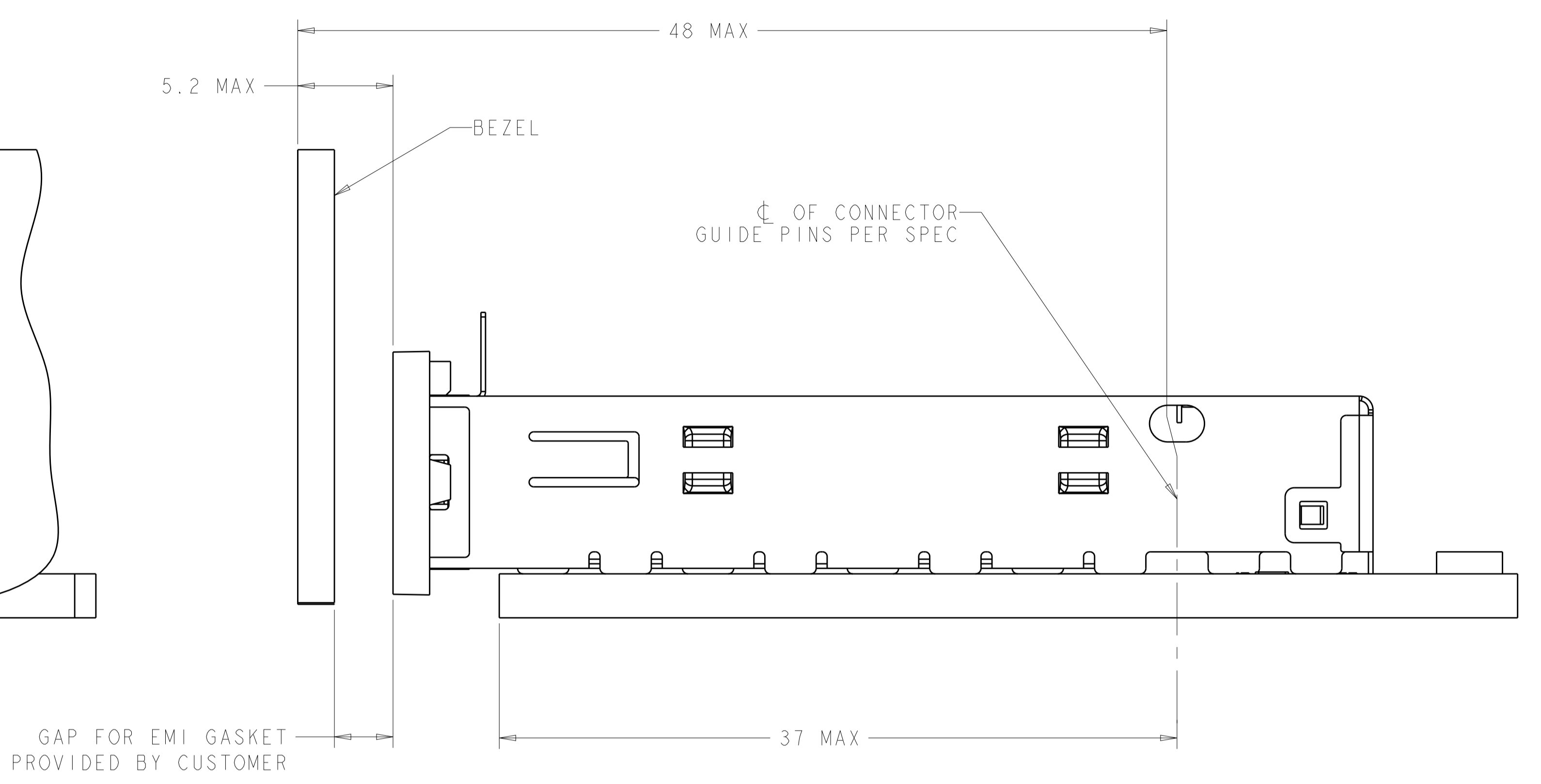
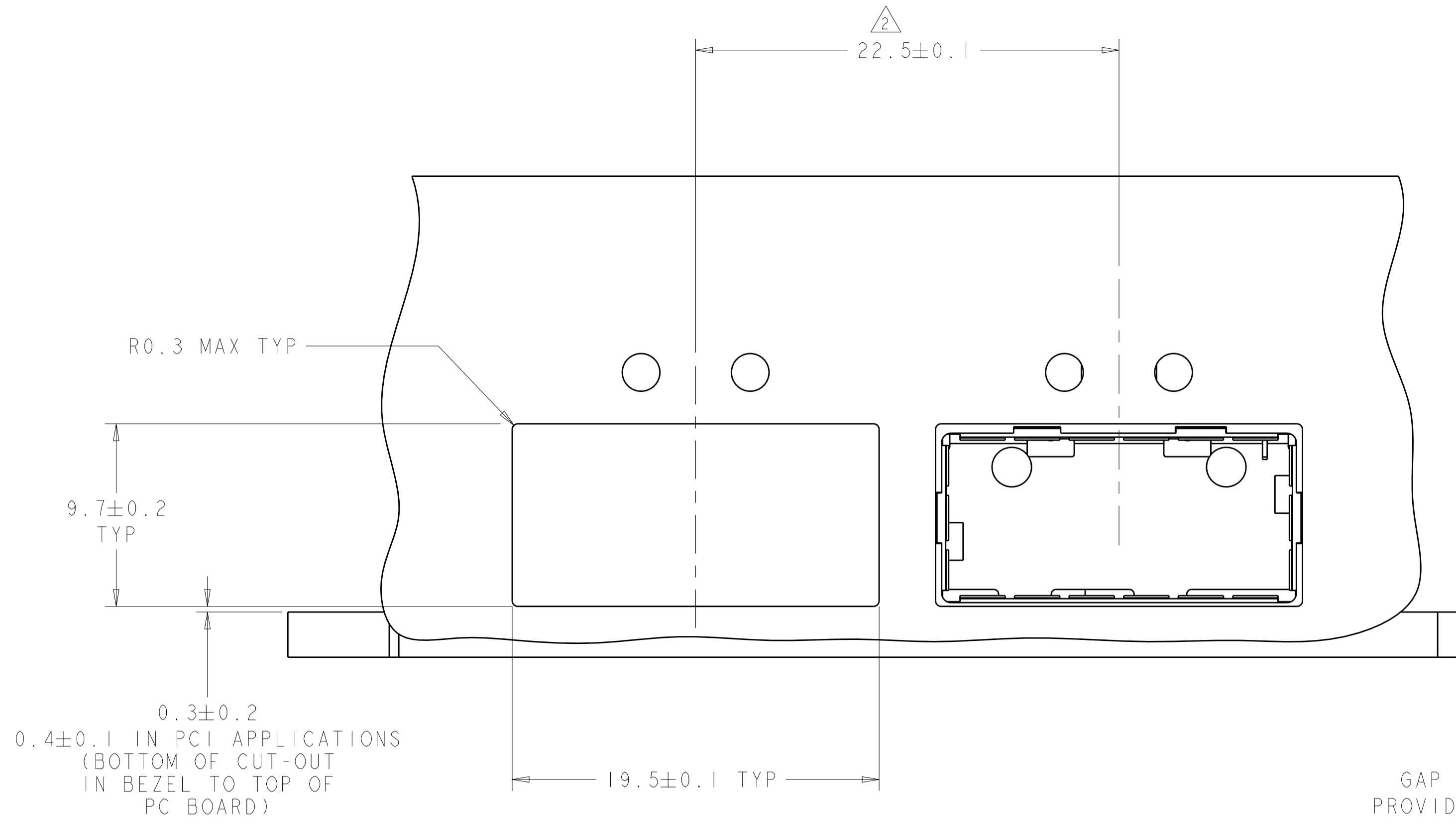

ONE SIDED CONFIGURATION

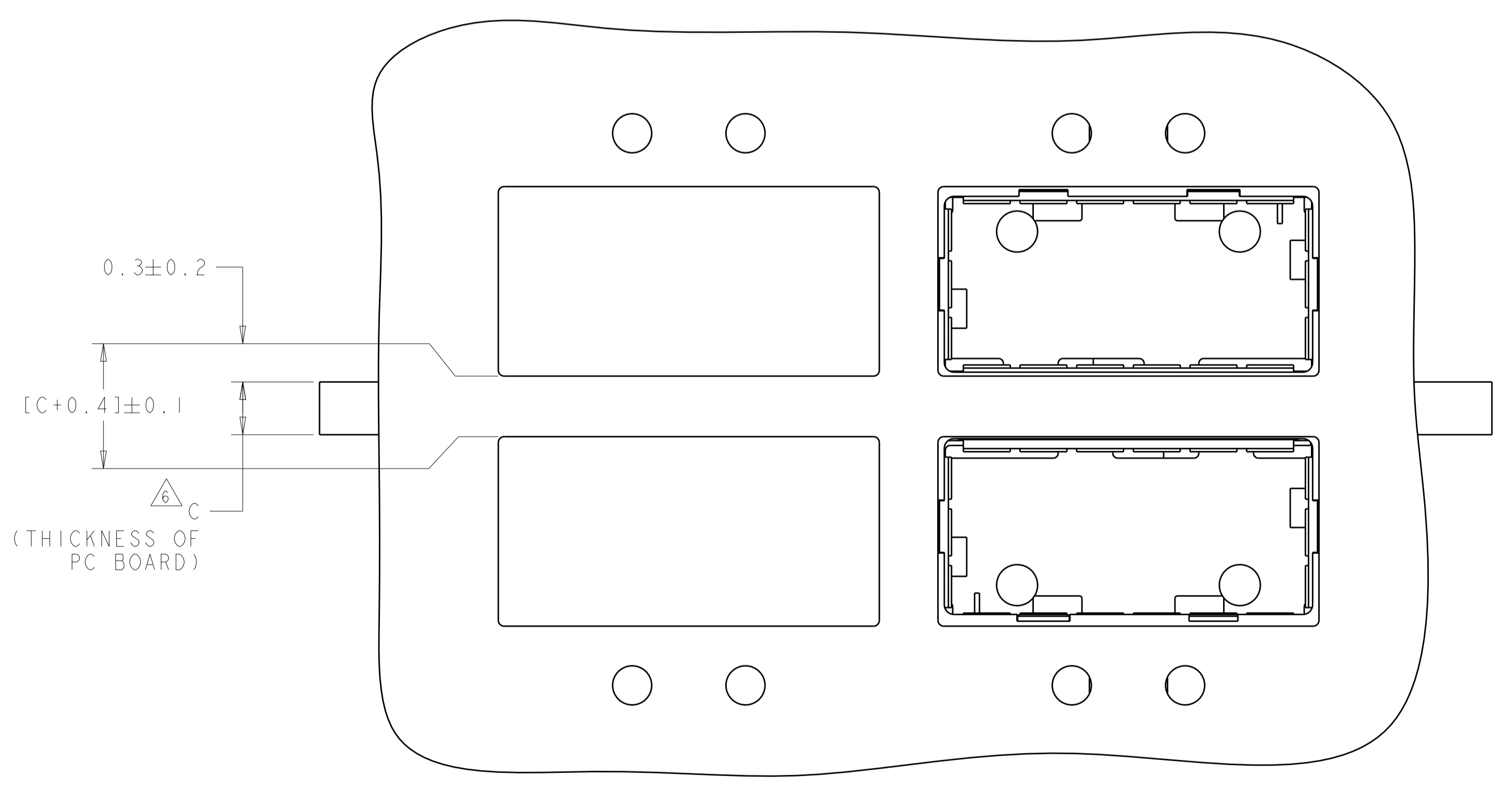

BELLY TO BELLY CONFIGURATION
SIMILAR TO ONE SIDED EXCEPT
WHERE NOTED

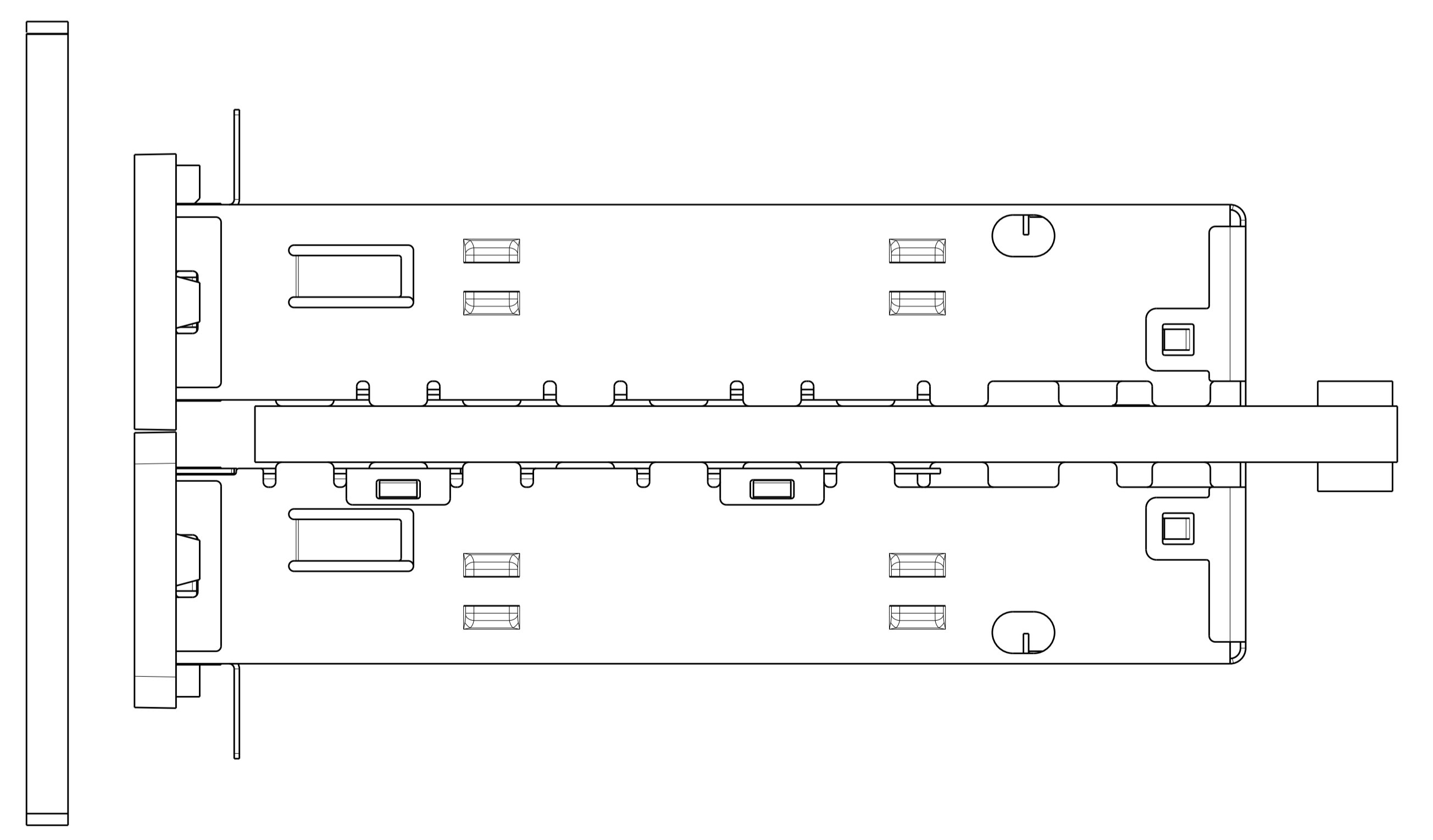

THIS DRAWING IS A CONTROLLED DOCUMENT.		OWN: 27JUN2011	TE Connectivity
DIMENSIONS: mm		CHK: 28JUN2011	
TOLERANCES UNLESS OTHERWISE SPECIFIED:		APPD: 30JUN2011	
0 PLC ±0.5 1 PLC ±0.13 2 PLC ±0.13 3 PLC ±0.013 4 PLC ±0.001 ANGLES ±0.0001		PRODUCT SPEC: 108-2286 APPLICATION SPEC: 114-13218 WEIGHT: -	
MATERIAL: -		FINISH: -	NAME: CAGE ASSEMBLY, BEHIND BEZEL, W/ LIGHT PIPE BRACKET, QSFP SIZE: A1 CAGE CODE: 00779 DRAWING NO: C=2170111 RESTRICTED TO: - Customer Drawing SCALE: 5:1 SHEET 2 OF 4 REV 2

LOC	DIST	REV	DATE	BY	APPV
GP	00				

REVISIONS					
REV	DATE	BY	APPV	DESCRIPTION	DATE
-	-	-	-	SEE SHEET 1	-

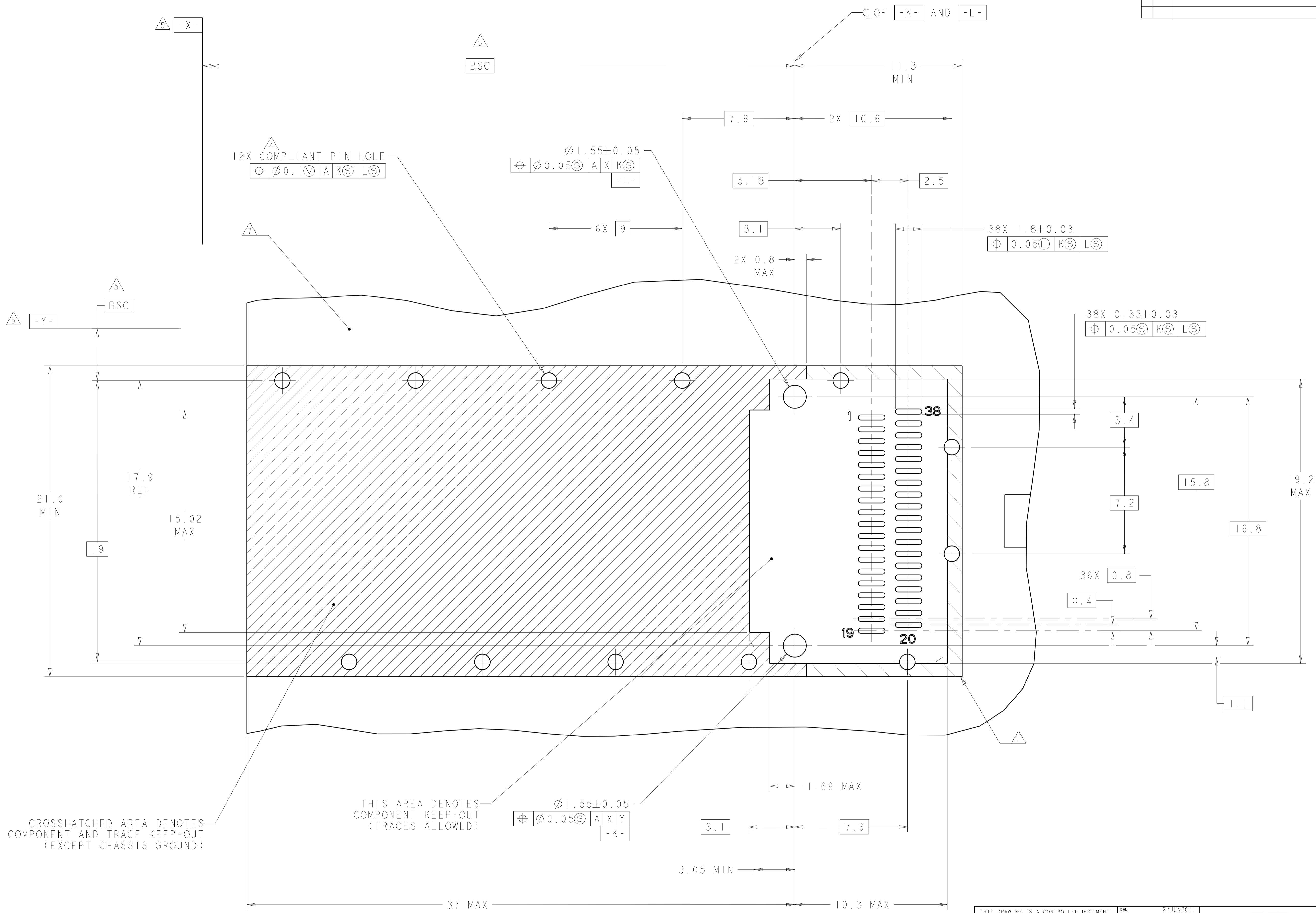

CROSSHATCHED AREA DENOTES COMPONENT AND TRACE KEEP-OUT (EXCEPT CHASSIS GROUND)

THIS AREA DENOTES COMPONENT KEEP-OUT (TRACES ALLOWED)

RECOMMENDED SINGLE-SIDE PC BOARD LAYOUT
 SCALE 8:1

THIS DRAWING IS A CONTROLLED DOCUMENT.		OWN: 27JUN2011	TE Connectivity
DIMENSIONS: mm		CHK: 28JUN2011	
TOLERANCES UNLESS OTHERWISE SPECIFIED:		APPV: 30JUN2011	NAME: CAGE ASSEMBLY, BEHIND BEZEL, W/ LIGHT PIPE BRACKET, QFP
0 PLC ±0.5	1 PLC ±0.13	PRODUCT SPEC: 108-2286	SIZE: A100779C=2170111
2 PLC ±0.13	3 PLC ±0.013	APPLICATION SPEC: 114-13218	RESTRICTED TO: -
4 PLC ±0.001	ANGLES ±0.0001	WEIGHT: -	SCALE: 5:1 SHEET 3 OF 4 REV 2
MATERIAL: -	FINISH: -	Customer Drawing	

LOC	DIST	REV	DATE	BY	APPD
GP	00				

REVISIONS					
REV	DATE	BY	APPD	DESCRIPTION	DATE
-	-	-	-	SEE SHEET 1	-

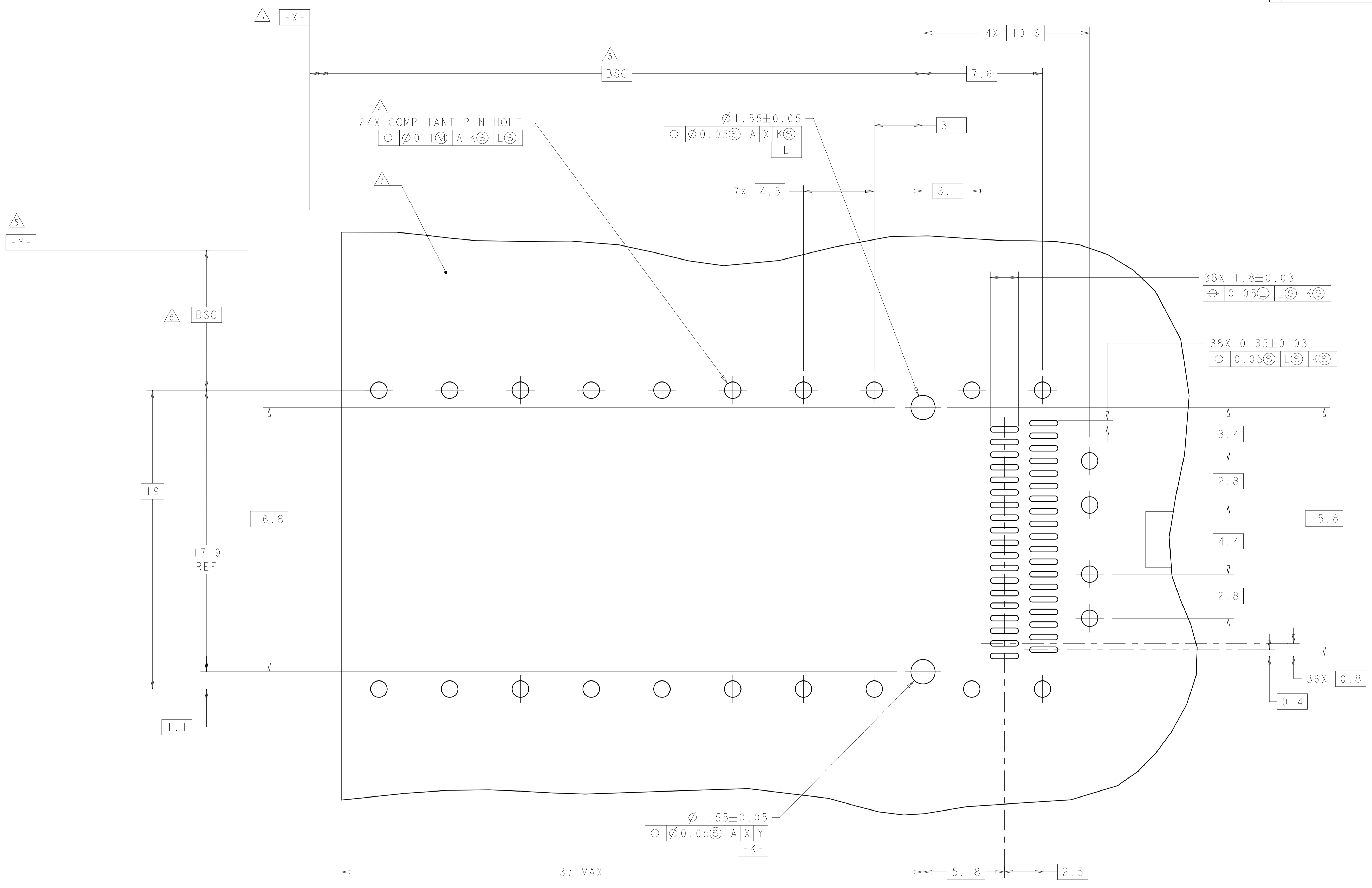

RECOMMENDED PCB LAYOUT
 BELLY TO BELLY CONFIGURATION
 SEE SHEET 3 FOR KEEP OUT AREAS
 SCALE 8:1

THIS DRAWING IS A CONTROLLED DOCUMENT.		OWN: 27JUN2011	TE Connectivity
DIMENSIONS: mm		CHK: 28JUN2011	
TOLERANCES UNLESS OTHERWISE SPECIFIED:		APPD: 30JUN2011	NAME: CAGE ASSEMBLY, BEHIND BEZEL, W/ LIGHT PIPE BRACKET, QSFP
0 PLC ±0.5	1 PLC ±0.5	PRODUCT SPEC 108-2286	SIZE: A100779C=2170111
2 PLC ±0.13	3 PLC ±0.013	APPLICATION SPEC 114-13218	RESTRICTED TO: -
4 PLC ±0.001	ANGLES ±0.001	WEIGHT: -	SCALE: 5:1
MATERIAL: -	FINISH: -	Customer Drawing	SHEET 4 OF 4
			REV 2