

Intellimod™ Module Dual-In-Line Intelligent Power Module 30 Amperes/600 Volts

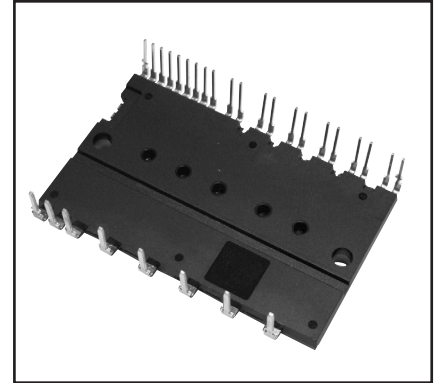
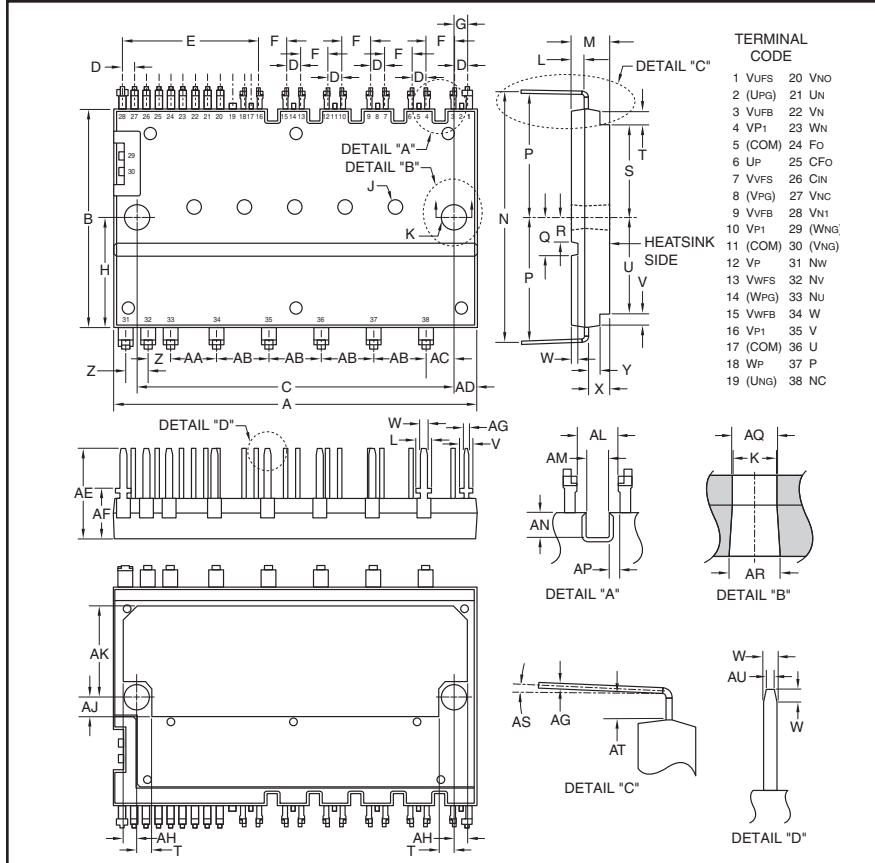

Description:
DIP-IPMs are intelligent power modules that integrate power devices, drivers, and protection circuitry in an ultra compact dual-in-line transfer-mold package for use in driving small three phase motors. Use of 5th generation IGBTs, DIP packaging, and application specific HVICs allow the designer to reduce inverter size and overall design time.

- Features:**
- Compact Packages
 - Single Power Supply
 - Integrated HVICs
 - Direct Connection to CPU
 - Reduced R_{th}

- Applications:**
- Refrigerators
 - Air Conditioners
 - Small Servo Motors
 - Small Motor Control

Ordering Information:
PS21767 is a 600V, 30 Ampere short pin DIP Intelligent Power Module.

Outline Drawing and Circuit Diagram

Dimensions	Inches	Millimeters
A	2.07	52.5
B	1.22	31.0
C	1.81±0.008	46.0±0.2
D	0.07±0.008	1.78±0.2
E	0.77	19.58
F	0.17±0.008	4.32±0.2
G	0.08±0.019	2.04±0.3
H	0.61	15.5
J	0.09 Dia. x 0.1 Depth	2.2 Dia. x 2.6 Depth
K	0.13 Dia.	3.3 Dia.
L	0.08	2.0
M	0.22	5.6
N	1.41±0.02	35.9±0.5
P	0.69	17.7
Q	0.216	5.5
R	0.14	3.5
S	0.503	12.78
T	0.09	2.2
U	0.53	13.5
V	0.06	1.5
W	0.04	1.0

Dimensions	Inches	Millimeters
X	0.06	1.55
Y	0.12	3.1±0.1
Z	0.13±0.019	3.3±0.3
AA	0.26±0.019	6.6±0.3
AB	0.3±0.019	7.62±0.3
AC	0.15±0.019	3.95±0.3
AD	0.13	3.25
AE	0.5	12.7
AF	0.28	7.1
AG	0.02	0.5
AH	0.067	1.7
AJ	0.11	2.8
AK	0.51	13.0
AL	0.114	2.9
AM	0.063	1.6
AN	0.068	1.75
AP	0.03	0.75
AQ	0.14 Dia.	3.5 Dia.
AR	0.145 Dia.	3.7 Dia.
AS	0° ~ 5°	
AT	0.078	1.96
AU	0.023	0.6

PS21767
Intellimod™ Module
Dual-In-Line Intelligent Power Module
 30 Amperes/600 Volts

Absolute Maximum Ratings, $T_j = 25^\circ\text{C}$ unless otherwise specified

Characteristics	Symbol	PS21767	Units
Power Device Junction Temperature*	T_j	-20 to 150	$^\circ\text{C}$
Storage Temperature	T_{stg}	-40 to 125	$^\circ\text{C}$
Case Operating Temperature (Note 1)	T_C	-20 to 100	$^\circ\text{C}$
Mounting Torque, M3 Mounting Screws	—	8.7	in-lb
Module Weight (Typical)	—	20	Grams
Heatsink Flatness (Note 2)	—	-50 to 100	μm
Self-protection Supply Voltage Limit (Short Circuit Protection Capability)**	$V_{\text{CC(prot.)}}$	400	Volts
Isolation Voltage, AC 1 minute, 60Hz Sinusoidal, Connection Pins to Heatsink Plate	V_{ISO}	2500	Volts

*The maximum junction temperature rating of the power chips integrated within the DIP-IPM is 150°C ($@T_C \leq 100^\circ\text{C}$).

** $V_D = 13.5 \sim 16.5\text{V}$, Inverter Part, $T_j = 125^\circ\text{C}$, Non-repetitive, Less than $2\mu\text{s}$

IGBT Inverter Sector

Collector-Emitter Voltage	V_{CES}	600	Volts
Each Collector Current, \pm ($T_C = 25^\circ\text{C}$)	I_C	30	Amperes
Each Peak Collector Current, \pm ($T_C = 25^\circ\text{C}$, Less than 1ms)	I_{CP}	60	Amperes
Supply Voltage (Applied between P- N_U , N_V , N_W)	V_{CC}	450	Volts
Supply Voltage, Surge (Applied between P- N_U , N_V , N_W)	$V_{\text{CC(surge)}}$	500	Volts
Collector Dissipation ($T_C = 25^\circ\text{C}$, per 1 Chip)	P_C	90.9	Watts

Control Sector

Supply Voltage (Applied between $V_{P1-V_{NC}}$, $V_{N1-V_{NC}}$)	V_D	20	Volts
Supply Voltage (Applied between $V_{UFB-U_{UFS}}$, $V_{VFB-V_{VFS}}$, $V_{WFB-W_{WFS}}$)	V_{DB}	20	Volts
Input Voltage (Applied between U_P , V_P , W_P-V_{NC} , U_N , V_N , W_N-V_{NC})	V_{IN}	-0.5 ~ $V_D+0.5$	Volts
Fault Output Supply Voltage (Applied between F_O-V_{NC})	V_{FO}	-0.5 ~ $V_D+0.5$	Volts
Fault Output Current (Sink Current at F_O Terminal)	I_{FO}	1	mA
Current Sensing Input Voltage (Applied between $C_{\text{IN}}-V_{\text{NC}}$)	V_{SC}	-0.5 ~ $V_D+0.5$	Volts

Note 1 – T_C Measure Point

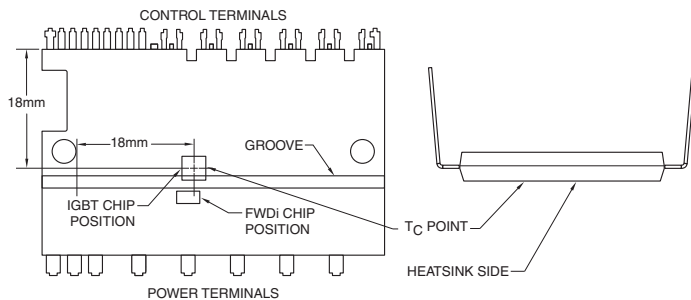

Note 2 – Flatness Measurement Position

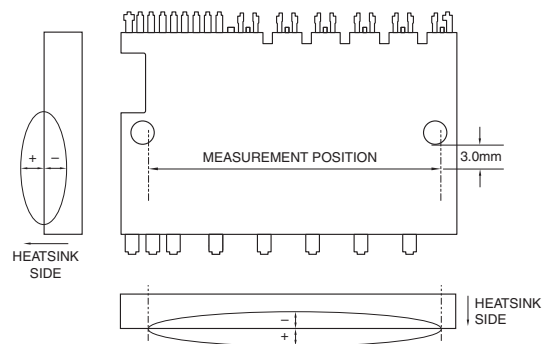

PS21767
Intellimod™ Module
Dual-In-Line Intelligent Power Module
 30 Amperes/600 Volts

Electrical and Mechanical Characteristics, $T_j = 25^\circ\text{C}$ unless otherwise specified

Characteristics	Symbol	Test Conditions	Min.	Typ.	Max.	Units
IGBT Inverter Sector						
Collector-Emitter Saturation Voltage	$V_{CE(sat)}$	$V_D = V_{DB} = 15\text{V}, I_C = 30\text{A}, V_{IN} = 5\text{V}, T_j = 25^\circ\text{C}$	—	1.60	2.10	Volts
		$V_D = V_{DB} = 15\text{V}, I_C = 30\text{A}, V_{IN} = 5\text{V}, T_j = 125^\circ\text{C}$	—	1.70	2.20	Volts
Diode Forward Voltage	V_{EC}	$-I_C = 30\text{A}, V_{IN} = 0\text{V}$	—	1.50	2.00	Volts
Inductive Load Switching Times	t_{on}		0.70	1.30	1.90	μs
	t_{rr}	$V_{CC} = 300\text{V}, V_D = V_{DB} = 15\text{V},$	—	0.30	—	μs
	$t_{C(on)}$	$I_C = 30\text{A}, T_j = 125^\circ\text{C},$	—	0.50	0.80	μs
	t_{off}	$V_{IN} = 0 - 5\text{V}, \text{Inductive Load}$	—	1.50	2.10	μs
	$t_{C(off)}$		—	0.40	0.60	μs
Collector Cutoff Current	I_{CES}	$V_{CE} = V_{CES}, T_j = 25^\circ\text{C}$	—	—	1.0	mA
		$V_{CE} = V_{CES}, T_j = 125^\circ\text{C}$	—	—	10	mA

Control Sector

Circuit Current	I_D	$V_{IN} = 5\text{V}$	Total of $V_{P1-V_{NC}}, V_{N1-V_{NC}}$	—	—	7.00	mA
			$V_{UFB-U}, V_{VFB-V}, V_{WFB-W}$	—	—	0.55	mA
		$V_{IN} = 0\text{V}$	Total of $V_{P1-V_{NC}}, V_{N1-V_{NC}}$	—	—	7.00	mA
			$V_{UFB-V_{UFS}}, V_{VFB-V_{VFS}}, V_{WFB-V_{WFS}}$	—	—	0.55	mA
Fault Output Voltage	V_{FOH}	$V_{SC} = 0\text{V}, F_O$ Terminal Pull-up to 5V by 10k Ω	4.9	—	—	Volts	
		$V_{SC} = 1\text{V}, I_{FO} = 1\text{mA}$	—	—	0.95	Volts	
Short Circuit Trip Level*	$V_{SC(ref)}$	$V_D = 15\text{V}$	0.43	0.48	0.53	Volts	
Input Current	I_{IN}	$V_{IN} = 5\text{V}$	1.0	1.5	2.0	mA	
Supply Circuit Under-voltage	UV_{DBt}	Trip Level, $T_j \leq 125^\circ\text{C}$	10.0	—	12.0	Volts	
Protection	UV_{DBr}	Reset Level, $T_j \leq 125^\circ\text{C}$	10.5	—	12.5	Volts	
		Trip Level, $T_j \leq 125^\circ\text{C}$	10.3	—	12.5	Volts	
		Reset Level, $T_j \leq 125^\circ\text{C}$	10.8	—	13.0	Volts	
		Trip Level, $T_j \leq 125^\circ\text{C}$	10.3	—	12.5	Volts	
Fault Output Pulse Width**	t_{FO}	$C_{FO} = 22\text{nF}$	1.0	1.8	—	ms	
ON Threshold Voltage	$V_{th(on)}$	Applied between	—	2.3	2.6	Volts	
OFF Threshold Voltage	$V_{th(off)}$	$U_P, V_P, W_P-V_{NC},$	0.8	1.4	—	Volts	
ON/OFF Threshold Hysteresis Voltage	$V_{th(hys)}$	U_N, V_N, W_N-V_{NC}	0.5	0.9	—	Volts	

* Short Circuit protection is only for the lower-arms. Please select the external shunt resistance such that the S_C trip level is less than 2.0 times the current rating.

**Fault signal is output when the low-arms short circuit or control supply under-voltage protective function works. The fault output pulse-width, t_{FO} , depends on the capacitance of C_{FO} according to the following approximate equation: $C_{FO} = 12.2 \times 10^{-6} \times t_{FO} [F]$.

PS21767
 Intellimod™ Module
 Dual-In-Line Intelligent Power Module
 30 Amperes/600 Volts

Thermal Characteristics

Characteristic	Symbol	Condition	Min.	Typ.	Max.	Units
Junction to Case*	$R_{th(j-c)Q}$	Inverter IGBT (Per 1/6 Module)	—	—	1.1	°C/Watt
	$R_{th(j-c)D}$	Inverter FWDi (Per 1/6 Module)	—	—	2.8	°C/Watt

Recommended Conditions for Use

Characteristic	Symbol	Condition	Min.	Typ.	Value	Units	
Supply Voltage	V_{CC}	Applied between P- N_U , N_V , N_W	0	300	400	Volts	
Control Supply Voltage	V_D	Applied between V_{P1} - V_{NC} , V_{N1} - V_{NC}	13.5	15.0	16.5	Volts	
	V_{DB}	Applied between V_{UFB} - V_{UFS} , V_{VFB} - V_{VFS} , V_{WFB} - V_{WFS}	13.0	15.0	18.5	Volts	
Control Supply Variation	dV_D , dV_{DB}	—	-1	—	1	V/ μ s	
Arm Shoot-through	t_{DEAD}	For Each Input Signal, $T_C \leq 100^\circ\text{C}$	2.0	—	—	μ s	
Blocking Time		$T_C \leq 100^\circ\text{C}$					
PWM Input Frequency	f_{PWM}	$T_C \leq 100^\circ\text{C}$, $T_j \leq 125^\circ\text{C}$	—	—	20	kHz	
Allowable Minimum	$P_{WIN(on)}^{**}$	—	0.3	—	—	μ s	
Input Pulse Width	$P_{WIN(off)}^{***}$	Below Rated Current	1.5	—	—	μ s	
		Between Rated Current and 1.7 Times Rated Current	3.0	—	—	μ s	
		Between 1.7 Times and 2.0 Times Rated Current	3.6	—	—	μ s	
		Wiring Inductance < 10nH					
V_{NC} Voltage Variation	V_{NC}	Between V_{NC} - N_U , N_V , N_W , (Including Surge)	-5.0	—	5.0	Volts	
Junction Temperature	T_j	—	-20	—	125	°C	

*-100 ~ +200 μ m of thermally conductive grease should be applied evenly to the contact surface between the DIP-IPM and heatsink. $R_{th(j-c)}$ is determined by the thickness and the thermal conductivity of the applied grease.

**The input signal with ON pulse less than $P_{WIN(on)}$ may make no response.

***DIP-IPM may make a delayed response (less than about 2 μ sec) or no response for the input signal with OFF pulse width less than $P_{WIN(off)}$. Refer to About Delayed Response Against Shorter Input OFF Signal than $P_{WIN(off)}$ (P-side Only) and Recommended Wiring Around the Shunt Resistor for details about N-line inductance.

Delayed Response Against Shorter Input OFF Signal than $P_{WIN(off)}$ (P-side Only)

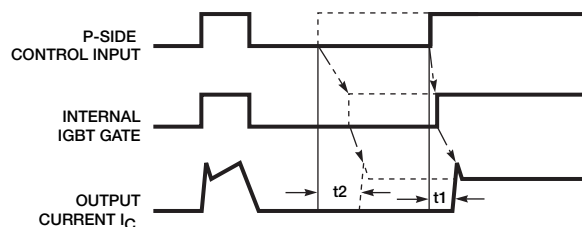

Solid Line – OFF Pulse Width > $P_{WIN(off)}$: Turn ON time t_1 .

Dotted Line – OFF Pulse Width < $P_{WIN(off)}$: Turn ON time t_2 .

PS21767
 Intellimod™ Module
 Dual-In-Line Intelligent Power Module
 30 Amperes/600 Volts

Short Circuit Protection (Lower-arms Only with External Shunt Resistor and RC Filter)

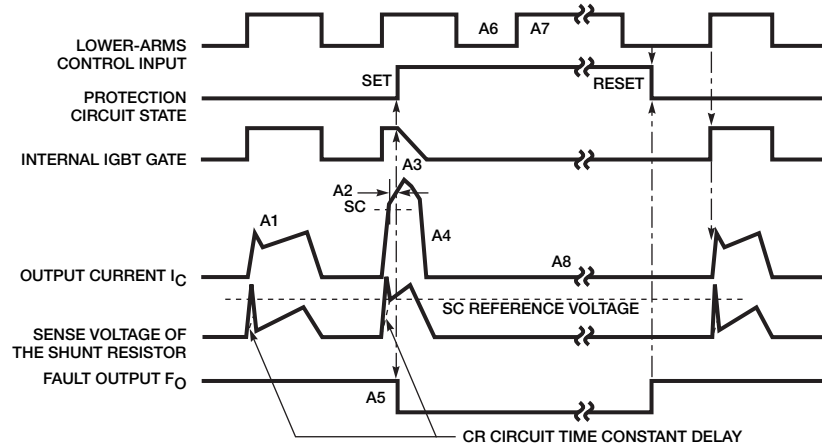

- A1: Normal operation – IGBT ON and carrying current.
- A2: Short Circuit current detection (SC trigger).
- A3: IGBT gate hard interruption.
- A4: IGBT turns OFF.
- A5: F_O timer operation starts. The pulse width of the F_O signal is set by the external capacitor C_{FO} .
- A6: Input "L" – IGBT OFF.
- A7: Input "H"
- A8: IGBT OFF state in spite of input "H".

Under-Voltage Protection (Lower-arm, UV_D)

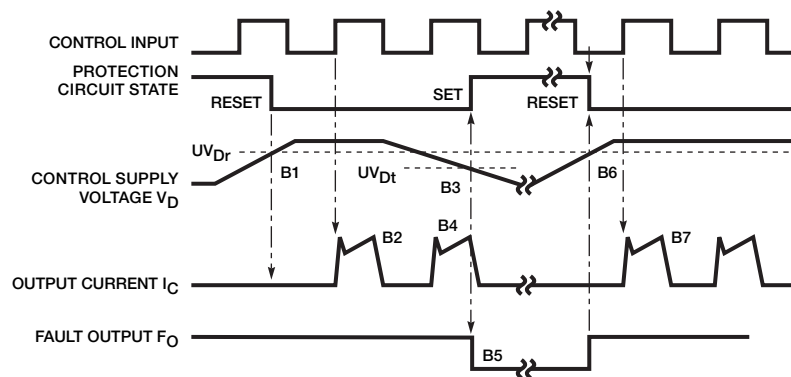

- B1: Control supply voltage rising – After the voltage level reaches UV_{Dr} , the drive circuit begins to work at the rising edge of the next input signal.
- B2: Normal operation – IGBT ON and conducting current.
- B3: Under-voltage trip (UV_{Dt}).
- B4: IGBT turns OFF regardless of the control input level.
- B5: F_O operation starts.
- B6: Under-voltage reset (UV_{Dr}).
- B7: Normal operation – IGBT ON and conducting current.

PS21767
 Intellimod™ Module
 Dual-In-Line Intelligent Power Module
 30 Amperes/600 Volts

Under-Voltage Protection (Upper-arm, UV_{DB})

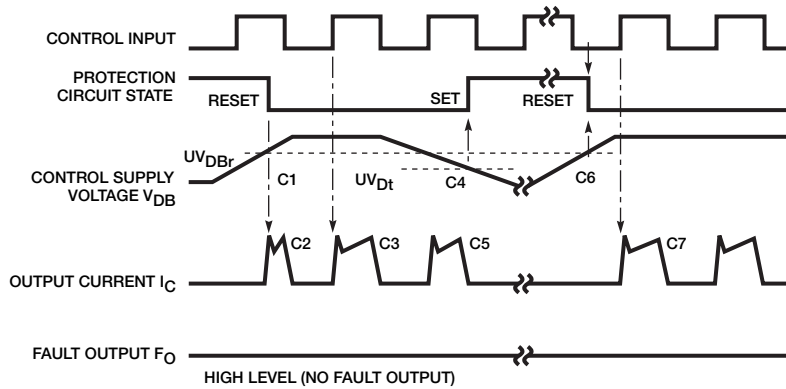

- C1: Control supply voltage rises – After the voltage level reaches UV_{Dt}, the drive circuit begins to work at the rising edge of the next input signal.
- C2: Protection circuit state reset – IGBT ON and conducting current.
- C3: Normal operation – IGBT ON and conducting current.
- C4: Under-voltage trip (UV_{Dt}).
- C5: IGBT OFF regardless of the control input level, but there is no F_O signal output.
- C6: Under-voltage reset (UV_{Dt}).
- C7: Normal operation – IGBT ON and conducting current.

Recommended MCU I/O Interface Circuit

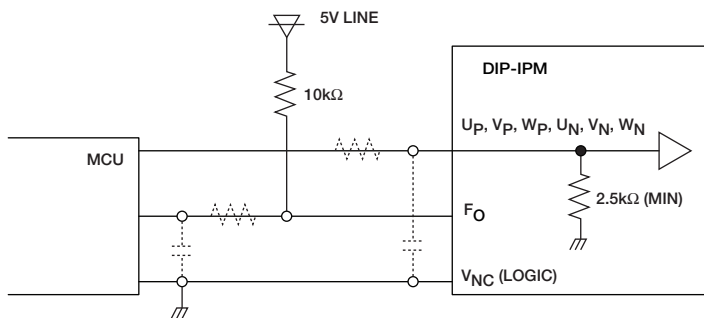

NOTE: RC coupling at each input (parts shown dotted) may change depending on the PWM control scheme used in the application and the wiring impedance of the printed circuit board. The DIP-IPM input signal section integrates a 2.5kΩ (min) pull-down resistor. Therefore, when using an external filtering resistor, care must be taken to satisfy the turn-on threshold voltage requirement.

Recommended Wiring Around the Shunt Resistor

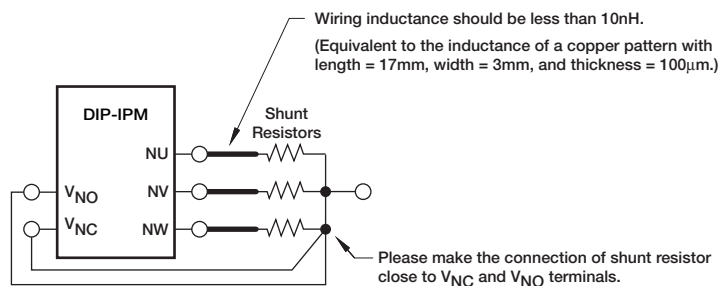

PS21767
Intellimod™ Module
Dual-In-Line Intelligent Power Module
 30 Amperes/600 Volts

Application Circuit

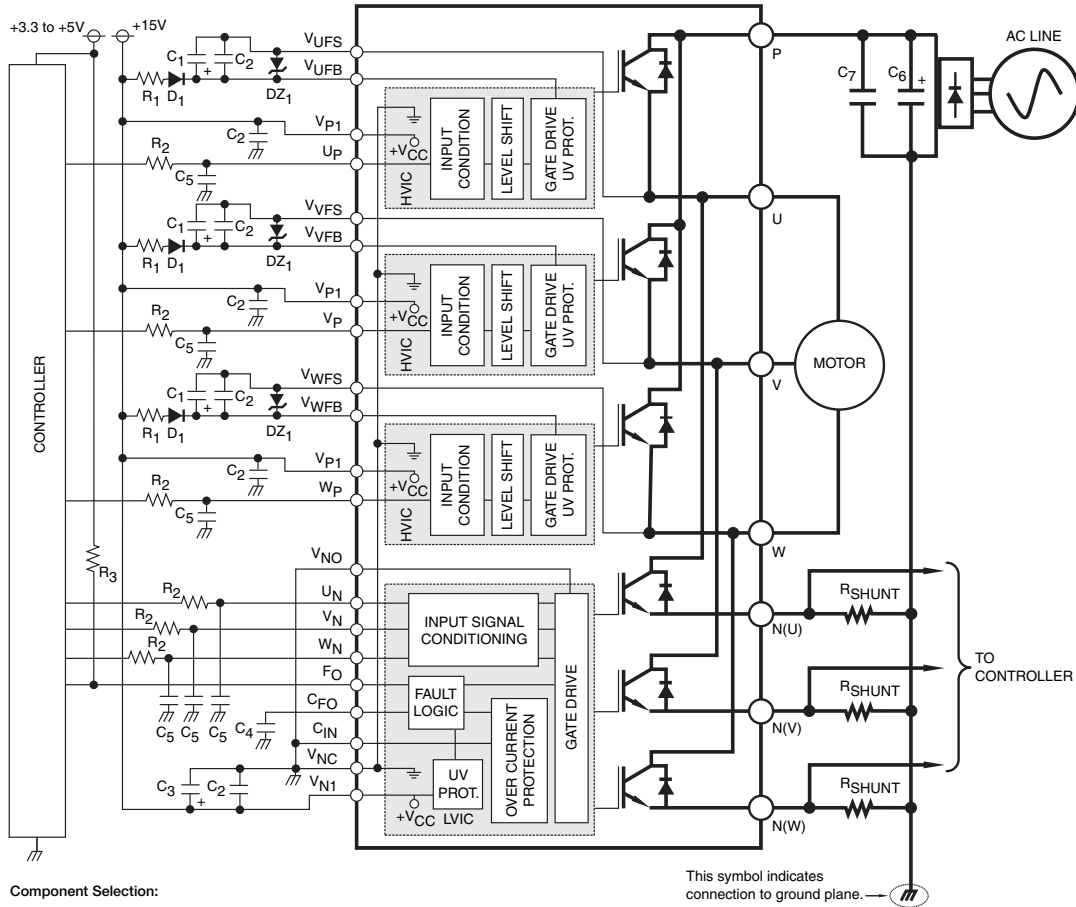

Component Selection:

Dsgn.	Typ. Value	Description
D ₁	1A, 600V	Boot strap supply diode – Ultra fast recovery
DZ ₁	16V, 0.25W	Control and boot strap supply over voltage suppression
C ₁	10-100uF, 50V	Boot strap supply reservoir – Electrolytic, long life, low Impedance, 105°C (Note 5)
C ₂	0.22-2.0uF, 50V	Local decoupling/High frequency noise filters – Multilayer ceramic (Note 5)
C ₃	10-100uF, 50V	Control power supply filter – Electrolytic, long life, low Impedance, 105°C (Note 5)
C ₄	22nF, 50V	Fault output timer capacitor
C ₅	100pF, 50V	Optional Input signal noise filter – Multilayer ceramic (Note 1)
C ₆	200-2000uF, 450V	Main DC bus filter capacitor – Electrolytic, long life, high ripple current, 105°C
C ₇	0.1-0.22uF, 450V	Surge voltage suppression capacitor – Polyester/Polypropylene film (Note 8)
R _{SHUNT}	5-100mohm	Current sensing resistor – Non-inductive, temperature stable, tight tolerance (Note 9)
R ₁	10 ohm	Boot strap supply inrush limiting resistor
R ₂	330 ohm	Optional control input noise filter (Note 1, Note 2)
R ₃	10k ohm	Fault output signal pull-up resistor (Note 3)

Notes:

- Input drive is active-high type. There is a 2.5kΩ(min.) pull-down resistor integrated in the IC input circuit. To prevent malfunction, the wiring of each input should be as short as possible. When using RC coupling circuit, make sure the input signal level meets the turn-on and turn-off threshold voltage. See application notes for details.
- Internal HVIC provides high voltage level shifting allowing direct connection of all six driving signals to the controller.
- F_O output is an open collector type. Pull up resistor (R₃) should be adjusted to current sink capability of the controller.
- To prevent input signal oscillations, minimize wire length to controller (~2cm). Additional RC filtering (C₅ etc.) may be required. If filtering is added be careful to maintain proper dead time and voltage levels. See application notes for details.
- All capacitors should be mounted as close to the terminals as possible. (C₁: good temperature, frequency characteristic electrolytic type, and C₂, C₃: good temperature, frequency and DC bias characteristic ceramic type are recommended.)
- Shows short circuit protection disabled. See application notes for use of short circuit protection.
- Local decoupling frequency filter capacitors must be connected as close as possible to the module's pins.
- The length of the DC link wiring between C₅, C₆, the DIP's P terminal and the shunt must be minimized to prevent excessive transient voltages. In particular C₆ should be mounted as close to the DIP as possible.
- Use high quality, tight tolerance current sensing resistor. Connect resistor as close as possible to the DIP's N terminal. Be careful to check for proper power rating. See application notes for calculation of resistance value.
- Inserting a Zener diode (24V/1W) between each pair of control supply terminals to prevent surge destruction is recommended.

PS21767
Intellimod™ Module
Dual-In-Line Intelligent Power Module
 30 Amperes/600 Volts

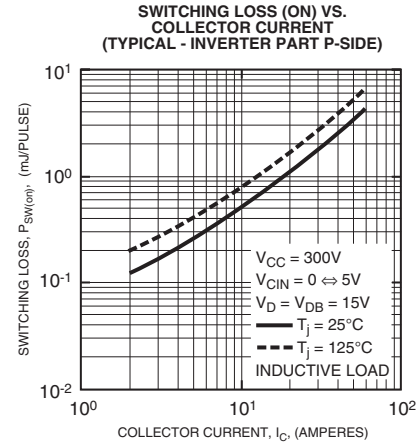
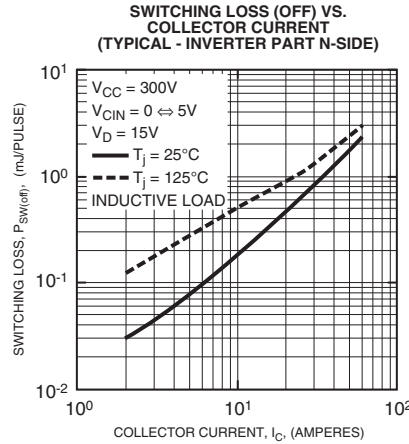
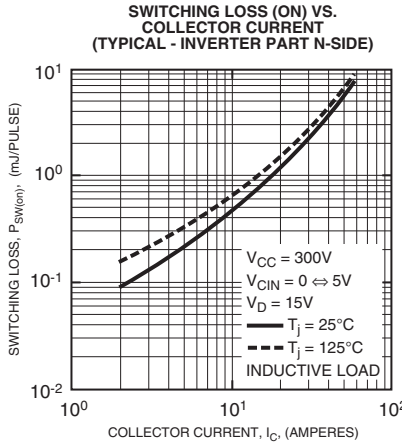
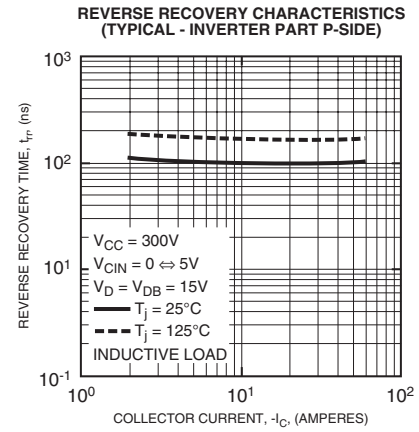
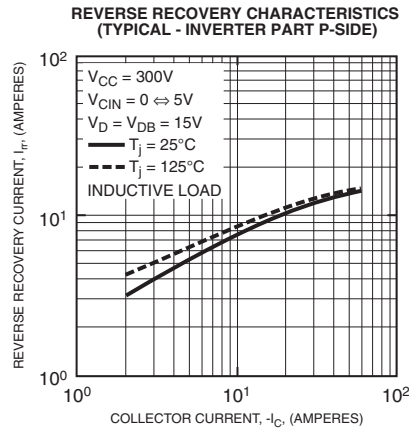
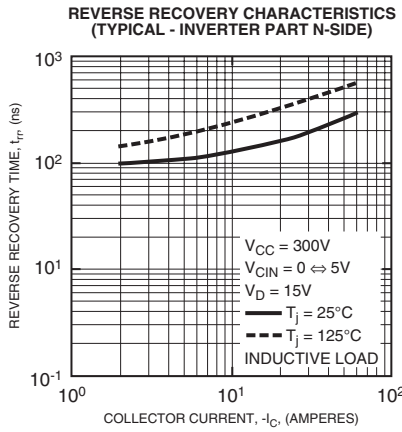
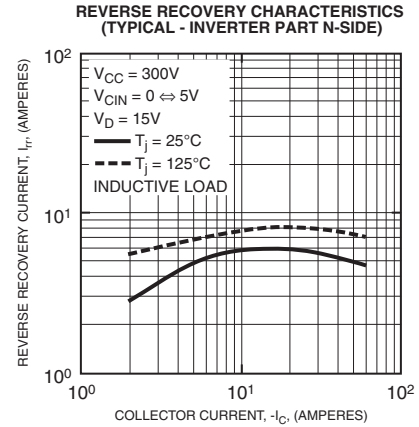
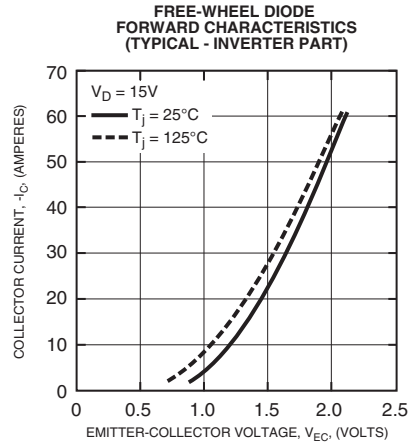
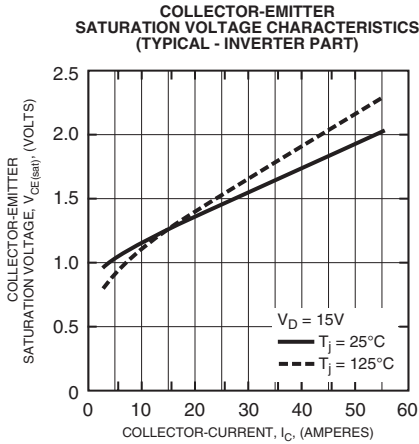

PS21767
Intellimod™ Module
Dual-In-Line Intelligent Power Module
30 Amperes/600 Volts

