

© COPYRIGHT 1982 BY AMP INCORPORATED, HARRISBURG, PA. ALL INTERNATIONAL RIGHTS RESERVED. AMP INCORPORATED PRODUCTS COVERED BY U.S. AND FOREIGN PATENTS AND /OR PATENTS PENDING.

REVISIONS			
LTR	DESCRIPTION	DATE	APPROVED
<i>A</i>	<i>REF. WAS 5035-10</i>	<i>11-21-89</i>	<i>JPG</i>
<i>A</i>	<i>REF LOC & DIST AD-4171</i>	<i>11-21-89</i>	<i>BF</i>
B	REV PER 0G3C-0449-00	30OCT00	JM

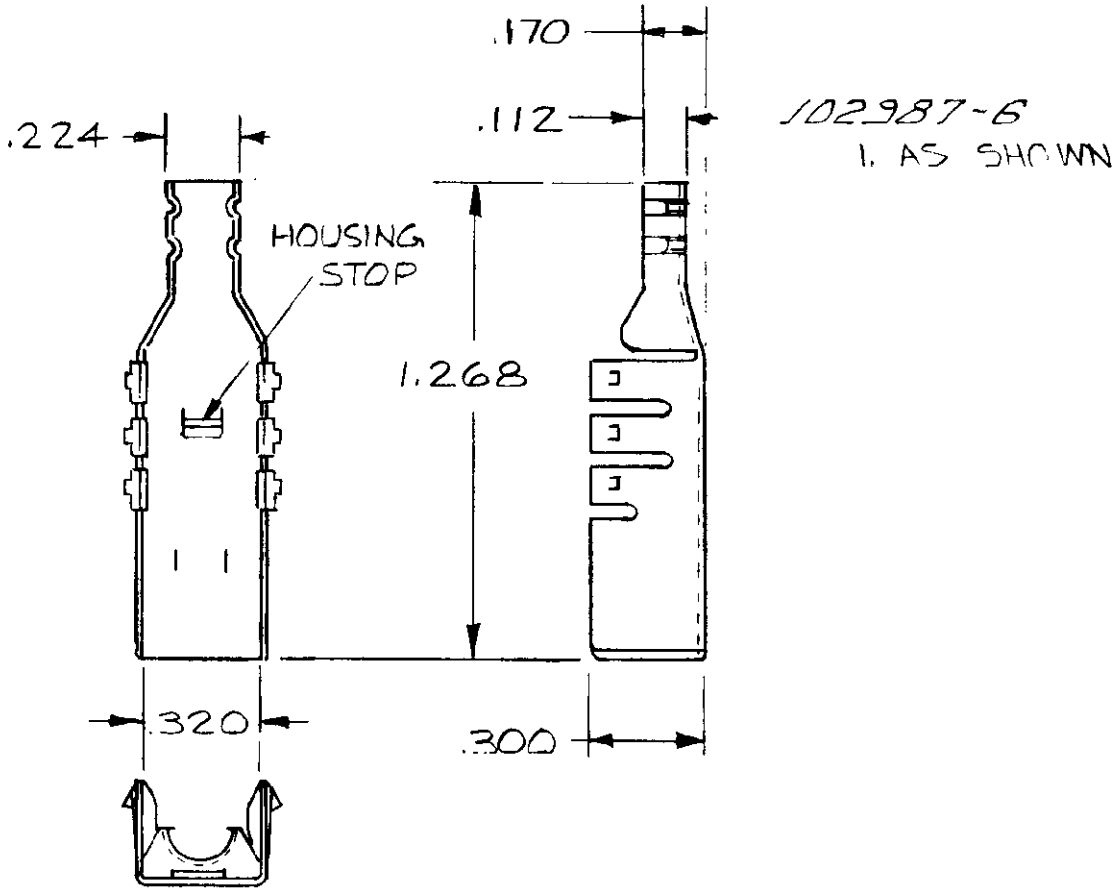

PART NO

UNLESS OTHERWISE SPECIFIED DIMENSIONS ARE IN INCHES. TOLERANCES ON: DECIMALS ± .010 ANGLES ± #

CONTRACT NO
 DR. *2.0 inch 7-1-82*
 APPD *J. Landis 7/20/82*



MATERIAL
 COPPER ALLOY
 .020 TH'K

APPD *J. Landis 7/20/82*
 APPD *J. Landis 7/20/82*

NAME SHELL, INNER, 180° CABLE EXIT, AMPMODU MT
 6 POSITION SHIELDED CONNECTOR

FINISH
 PRE-TINNED
 .000030 MIN.

DESIGN APPD
 OTHER APPD

SIZE **A** CODE IDENT NO **00779** DRAWING NO *102987*
 SCALE N.T.S. SHEET *1 OF 1*