



AK93C85A / 95A / 10A

16K / 32K / 64Kbit Serial CMOS EEPROM

Features

- ADVANCED CMOS EEPROM TECHNOLOGY
- READ/WRITE NON-VOLATILE MEMORY
- WIDE VCC OPERATION ... V_{CC} = 1.8V ~ 5.5V
- AK93C85A ···16384 bits, 1024 × 16 organization
 AK93C95A ···32768 bits, 2048 × 16 organization
 AK93C10A ···65536 bits, 4096 × 16 organization
- SERIAL INTERFACE
 - Interfaces with popular microcontrollers and standard microprocessors
- LOW POWER CONSUMPTION
 - 0.4mA max. Read Operation
 - 0.8μA Max. Standby
- HIGH RELIABILITY
 - Endurance : 100K cycles
 - Data Retention : 10 years
- Automatic address increment (READ)
- Automatic write cycle time-out with auto-ERASE (Max. 8ms : V_{CC}=4.5V ~ 5.5V)
- Busy/Ready status signal
- Software controlled write protection
- IDEAL FOR LOW DENSITY DATA STORAGE
 - Low cost, space saving, 8-pin package

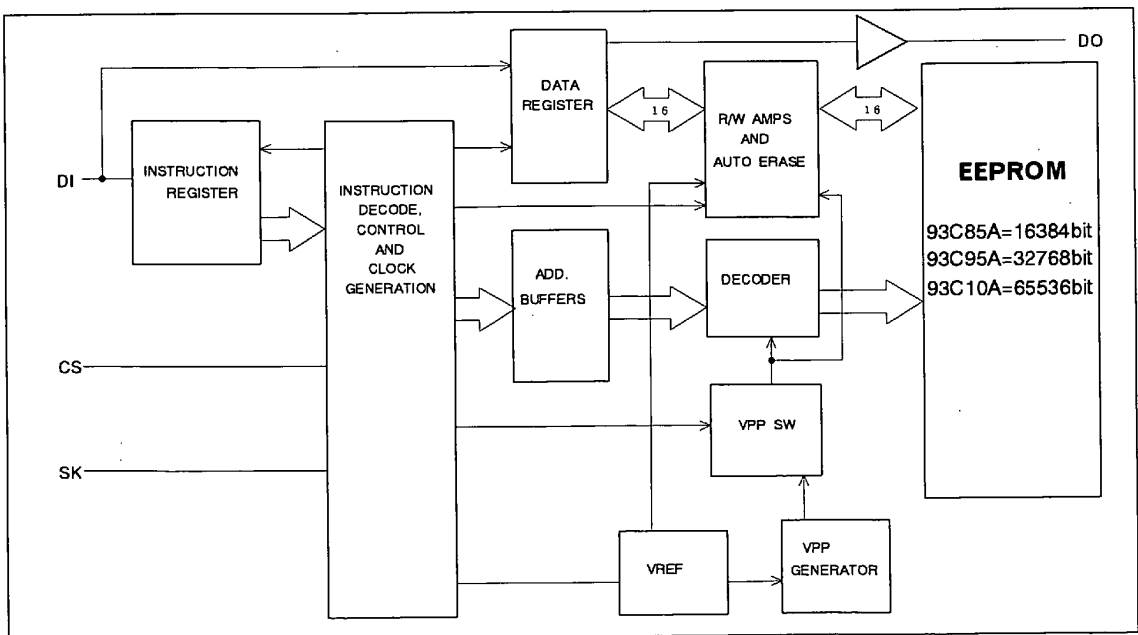

Block Diagram

General Description

The AK93C85A/95A/10A is a 16384/32768/65536-bit serial CMOS EEPROM divided into 1024/2048/4096 registers of 16 bits each. The AK93C85A/95A/10A has 4 instructions such as READ, WRITE, EWEN and EWDS. Those instructions control the AK93C85A/95A/10A.

The AK93C85A/95A/10A can operate full function under wide operating voltage range from 1.8V to 5.5V. The charge up circuit is integrated for high voltage generation that is used for write operation.

A serial interface of AK93C85A/95A/10A, consisting of chip select (CS), serial clock (SK), data-in (DI) and data-out (DO), can easily be controlled by popular microcontrollers or standard microprocessors.

AK93C85A/95A/10A takes in the write data from data input pin (DI) to a register synchronously with rising edge of input pulse of serial clock pin (SK). And at read operation, AK93C85A/95A/10A takes out the read data from a register to data output pin (DO) synchronously with rising edge of SK.

The DO pin is usually in high impedance state. The DO pin outputs "L" or "H" in case of data output or $\overline{\text{Busy/Ready}}$ signal output.

• Software controlled write protection

When Vcc is applied to the part, the part automatically powers up in the ERASE/WRITE Disable state. In the ERASE/WRITE disable state, execution of WRITE instruction is disabled. Before WRITE instruction is executed, EWEN instruction must be executed. The ERASE/WRITE enable state continues until EWDS instruction is executed or Vcc is removed from the part.

Execution of a read instruction is independent of both EWEN and EWDS instructions.

• $\overline{\text{Busy/Ready}}$ status signal

After a write instruction, the DO output serves as a $\overline{\text{Busy/Ready}}$ status indicator. After the falling edge of the CS initiates the self-timed programming cycle, the DO indicates the $\overline{\text{Busy/Ready}}$ status of the chip if the CS is brought high after a minimum of 250ns (Tcs). DO=logical "0" indicates that programming is still in progress. DO=logical "1" indicates that the register at the address specified in the instruction has been written with the new data pattern contained in the instruction and the part is ready for a next instruction.

The $\overline{\text{Busy/Ready}}$ status indicator is only valid when CS is active (high). When CS is low, the DO output goes into a high impedance state.

The $\overline{\text{Busy/Ready}}$ signal outputs until a start bit (Logic"1") of the next instruction is given to the part.

■ Type of Products

Model	Memory size	Temp.Range	Vcc	Package
AK93C85AF	16Kbits	-40°C~85°C	1.8V~5.5V	8pin Plastic SOP
AK93C85AM		-40°C~85°C	1.8V~5.5V	8pin Plastic SSOP
AK93C95AF	32Kbits	-40°C~85°C	1.8V~5.5V	8pin Plastic SOP
AK93C10AF	64Kbits	-40°C~85°C	1.8V~5.5V	8pin Plastic SOP

Pin arrangement

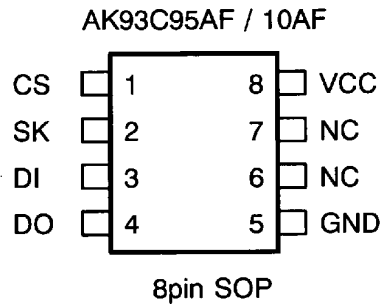
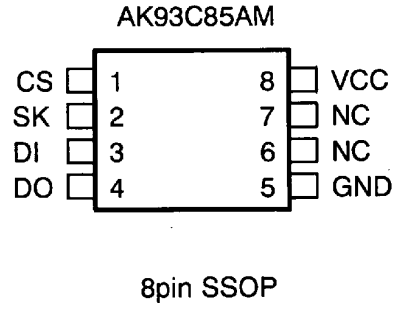
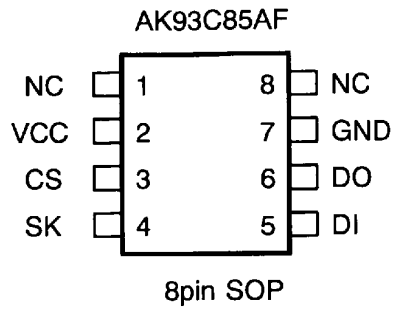

Pin Name	Function
CS	Chip Select
SK	Serial Data Clock
DI	Serial Data Input
DO	Serial Data Output
GND	Ground
Vcc	Power Supply
NC	Not Connected

Functional Description

The AK93C85A/95A/10A has 4 instructions such as READ, WRITE, EWEN and EWDS. A valid instruction consists of a Start Bit (Logic"1"), the appropriate Op Code and the desired memory Address location. The CS pin must be brought low for a minimum of 250ns (Tcs) between each instruction when the instruction is continuously executed.

Instruc- tion	Start Bit	Op Code	Address	Data	Comments
READ	1	10	A9-A0	D15-D0	Reads data stored in memory, at specified address.
WRITE	1	01	A9-A0	D15-D0	Writes register.
EWEN	1	00	11XXXXXXXX		Write enable must precede all programming modes.
EWDS	1	00	00XXXXXXXX		Disables all programming instructions.
WRAL	1	00	01XXXXXXXX	D15-D0	Writes all registers.

table1. Instruction Set for the AK93C85A

Instruc- tion	Start Bit	Op Code	Address	Data	Comments
READ	1	10	A10-A0	D15-D0	Reads data stored in memory, at specified address.
WRITE	1	01	A10-A0	D15-D0	Writes register.
EWEN	1	00	11XXXXXXXXXX		Write enable must precede all programming modes.
EWDS	1	00	00XXXXXXXXXX		Disables all programming instructions.
WRAL	1	00	01XXXXXXXXXX	D15-D0	Writes all registers.

table2. Instruction Set for the AK93C95A

Instruc- tion	Start Bit	Op Code	Address	Data	Comments
READ	1	10	A11-A0	D15-D0	Reads data stored in memory, at specified address.
WRITE	1	01	A11-A0	D15-D0	Writes register.
EWEN	1	00	11XXXXXXXXXX		Write enable must precede all programming modes.
EWDS	1	00	00XXXXXXXXXX		Disables all programming instructions.
WRAL	1	00	01XXXXXXXXXX	D15-D0	Writes all registers.

table3. Instruction Set for the AK93C10A

- (Note)
- The WRAL instruction are used for factory function test only.
User can't use the WRAL instruction.
 - The AK93C85A/95A/10A perceives the start bit in the logic"1" and also "01".

Write

The write instruction is followed by 16 bits of data to be written into the specified address.

AK93C85A : After the last bit of data is put on the DI pin, the CS pin must be brought low before the next rising edge of the SK clock. This falling edge of the CS initiates the self-timed programming cycle. The DO indicates the $\overline{\text{Busy}}$ /Ready status of the chip if the CS is brought high after a minimum of 250ns (T_{cs}).

AK93C95A/10A : The self-timed programming cycle is initiated on the rising edge of the SK clock as the last data bit (D0) is clocked in. The DO indicates the $\overline{\text{Busy}}$ /Ready status of the chip after the self-timed programming cycle is initiated.

The $\overline{\text{Busy}}$ /Ready status indicator is only valid when CS is active (high). When CS is low, the DO output goes into a high impedance state. The $\overline{\text{Busy}}$ /Ready signal outputs until a start bit (Logic "1") of the next instruction is given to the part.

DO=logical "0" indicates that programming is still in progress. DO=logical "1" indicates that the register at the address specified in the instruction has been written with the new data pattern contained in the instruction and the part is ready for a next instruction.

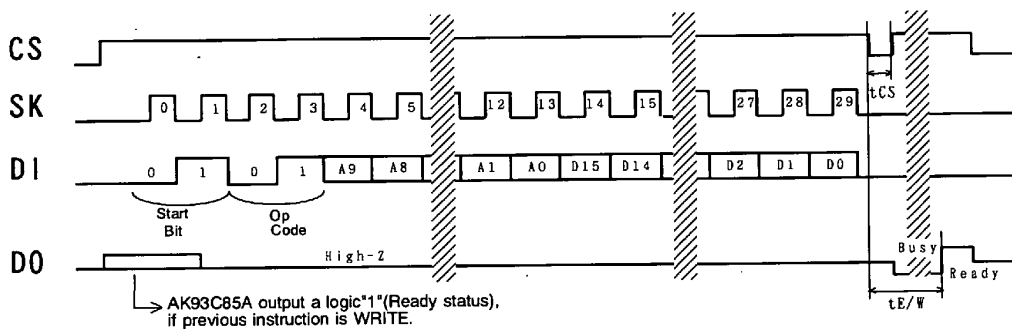

WRITE (AK93C85A)

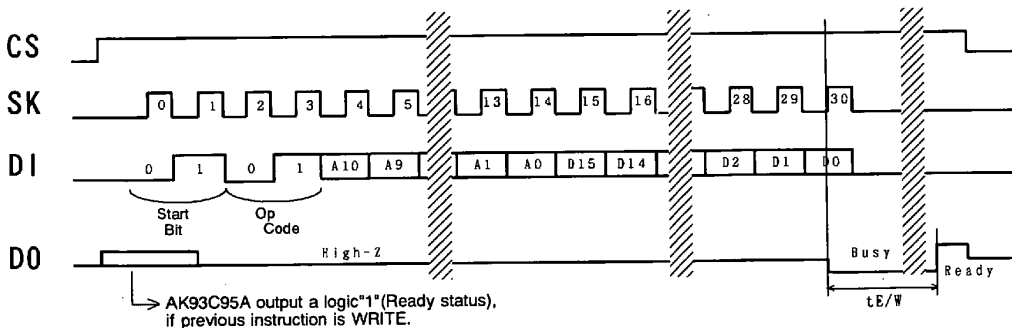

WRITE (AK93C95A)

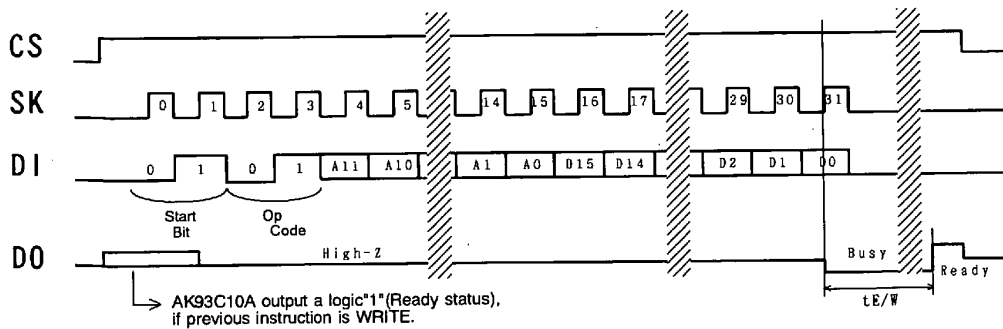

WRITE (AK93C10A)

Read

The read instruction is the only instruction which outputs serial data on the DO pin. Following the Start bit, first Op code and address are decoded, then the data from the selected memory location is available at the DO pin. A dummy bit (logical "0") precedes the 16-bit data from the selected memory location. The output data changes are synchronized with the rising edges of the serial clock (SK). The data in the next address can be read sequentially by continuing to provide clock. The address automatically cycles to the next higher address after the 16bit data shifted out.

- AK93C85A • • When the highest address is reached (\$3FF), the address counter rolls over to address \$000 allowing the read cycle to be continued indefinitely.
- AK93C95A • • When the highest address is reached (\$7FF), the address counter rolls over to address \$000 allowing the read cycle to be continued indefinitely.
- AK93C10A • • When the highest address is reached (\$FFF), the address counter rolls over to address \$000 allowing the read cycle to be continued indefinitely.

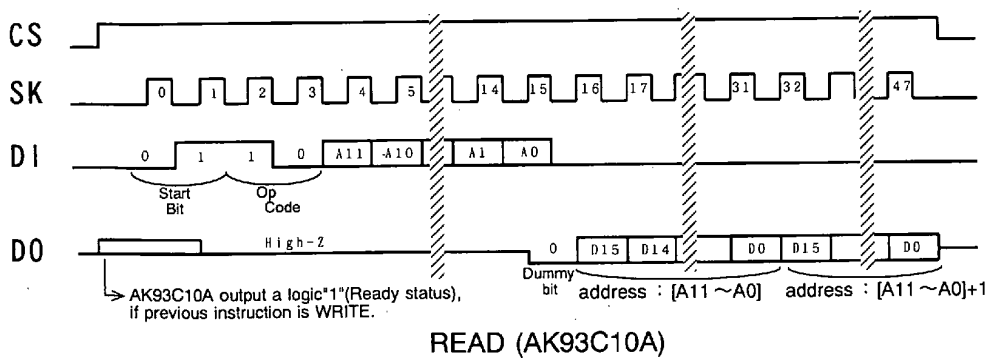
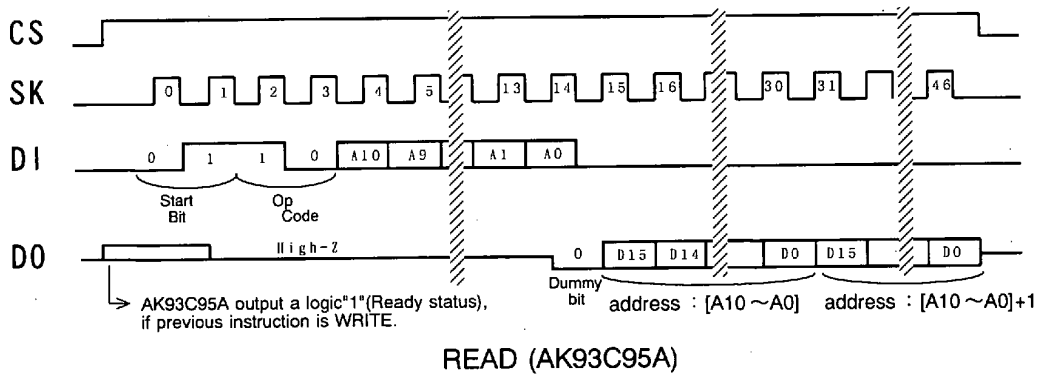
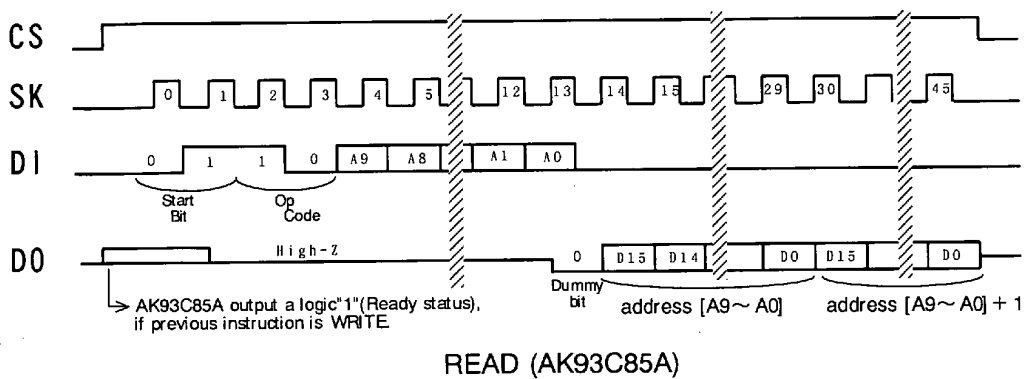

EWEN / EWDS

When Vcc is applied to the part, the part automatically powers up in the ERASE/WRITE Disable state. In the ERASE/WRITE disable state, execution of WRITE instruction is disable. Before WRITE instruction is executed, EWEN instruction must be executed. The ERASE/WRITE enable state continues until EWDS instruction is executed or Vcc is removed from the part.

Execution of a read instruction is independent of both EWEN and EWDS instructions.

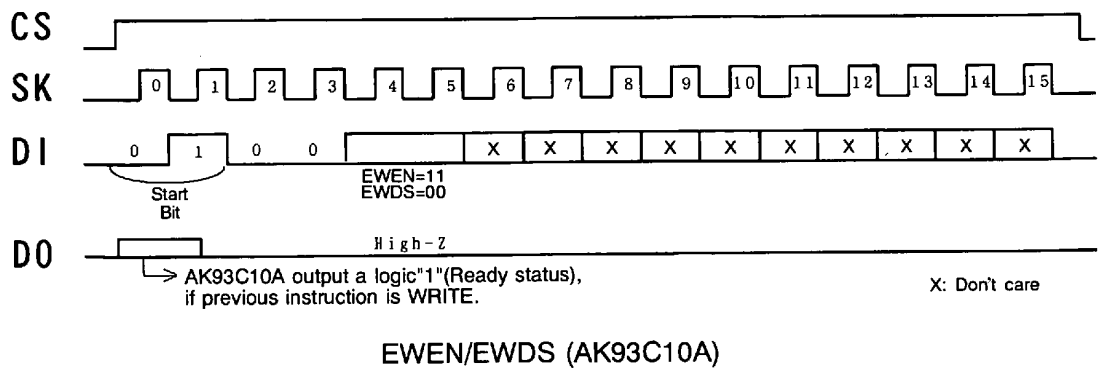
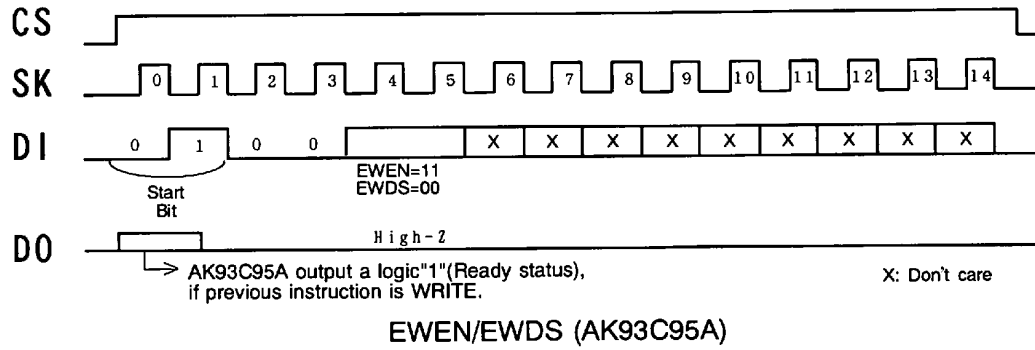
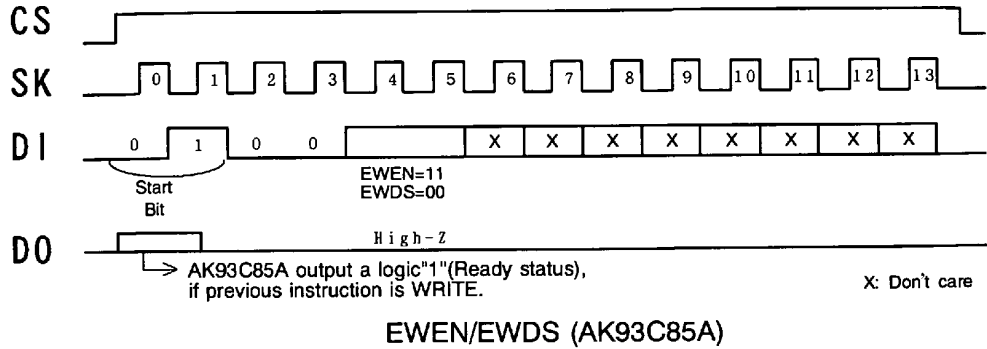

Absolute Maximum Ratings

Parameter	Symbol	Min	Max	Unit
Power Supply	VCC	-0.6	+7.0	V
All Input Voltages with Respect to Ground	VIO	-0.6	VCC+0.6	V
Ambient storage temperature	Tst	-65	+150	°C

Stress above those listed under "Absolute Maximum Ratings" may cause permanent damage to the device. This is a stress rating only and functional operation of the device at these or any other conditions above those indicated in the operational sections of the specification is not implied. Exposure to absolute maximum conditions for extended periods may affect device reliability.

Recommended Operating Condition

Parameter	Symbol	Min	Max	Unit
Power Supply	VCC	1.8	5.5	V
Ambient Operating Temperature	Ta	-40	+85	°C

Electrical Characteristics

(1) D.C. ELECTRICAL CHARACTERISTICS

(1.8V ≤ V_{CC} ≤ 5.5V, -40°C ≤ T_a ≤ 85°C, unless otherwise specified)

Parameter	Symbol	Condition	Min.	Max.	Unit
Current Dissipation (WRITE)	ICC1	VCC=5.5V, tSKP=1us, *1		5.5	mA
	ICC2	VCC=1.8V, tSKP=4us, *1		3.0	mA
Current Dissipation (READ,EWEN,EWDS)	ICC3	VCC=5.5V, tSKP=1us, *1		0.4	mA
	ICC4	VCC=1.8V, tSKP=4us, *1		0.1	mA
Current Dissipation (Standby)	ICCSB	VCC=5.5V *2		0.8	uA
Input High Voltage	VIH		0.8 × VCC	VCC+0.5	V
Input Low Voltage	VIL		-0.1	0.2 × VCC	V
Output High Voltage	VOH1	2.5V ≤ VCC ≤ 5.5V IOH=-0.1mA	0.8 × VCC		V
	VOH2	1.8V ≤ VCC < 2.5V IOH=-0.1mA	0.8 × VCC		V
Output Low Voltage	VOL1	2.5V ≤ VCC ≤ 5.5V IOL=1.0mA		0.4	V
	VOL2	1.8V ≤ VCC < 2.5V IOL=0.1mA		0.4	V
Input Leakage	ILI	VCC=5.5V, VIN=5.5V		±1.0	uA
Output Leakage	ILO	VCC=5.5V VOUT=5.5V, CS=GND		±1.0	uA

*1: VIN=VIH/VIL, DO=Open

*2: VIN=VCC/GND, CS=GND, DO=Open

(2) A.C. ELECTRICAL CHARACTERISTICS

(1.8V≤V_{CC}≤5.5V, -40°C≤T_a≤85°C, unless otherwise specified)

Parameter	Symbol	Condition	Min.	Max.	Unit
SK Cycle Time	tSKP1	4.5V≤V _{CC} ≤5.5V	1.0		us
	tSKP2	2.0V≤V _{CC} <4.5V	2.0		us
	tSKP3	1.8V≤V _{CC} <2.0V	4.0		us
SK Pulse Width	tSKW1	4.5V≤V _{CC} ≤5.5V	500		ns
	tSKW2	2.0V≤V _{CC} <4.5V	1.0		us
	tSKW3	1.8V≤V _{CC} <2.0V	2.0		us
CS Setup Time	tCSS		100		ns
CS Hold Time	tCSH		0		ns
Data Setup Time	tDIS		200		ns
Data Hold Time	tDIH		200		ns
Output delay	tPD1	4.5V≤V _{CC} ≤5.5V, *3		500	ns
	tPD2	2.0V≤V _{CC} <4.5V, *3		1.0	us
	tPD3	1.8V≤V _{CC} <2.0V, *3		2.0	us
Selftimed Programming Time	tE/W1	4.5V≤V _{CC} ≤5.5V		8	ms
	tE/W2	1.8V≤V _{CC} <4.5V		10	ms
Min CS Low Time	tCS		250		ns
CS to Status Valid1	tSV	CL=100pF		500	ns
CS to Status Valid2	tSVV	CL=100pF		1000	ns
CS to Output High-Z	tOZ1	2.0V≤V _{CC} ≤5.5V		100	ns
	tOZ2	1.8V≤V _{CC} <2.0V		250	ns

*3:CL=100pF

Synchronous Data timing

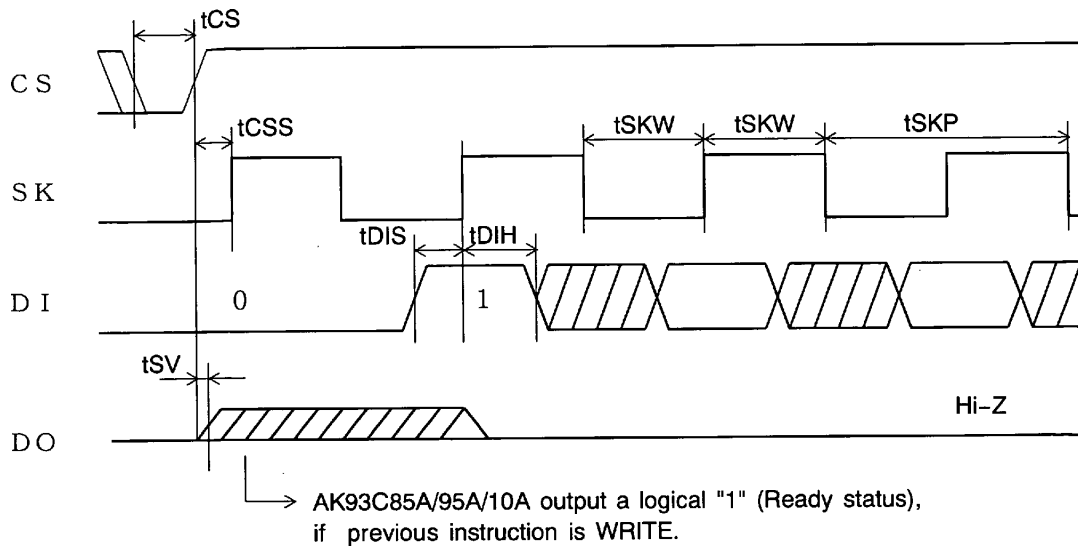

The Start of Instruction

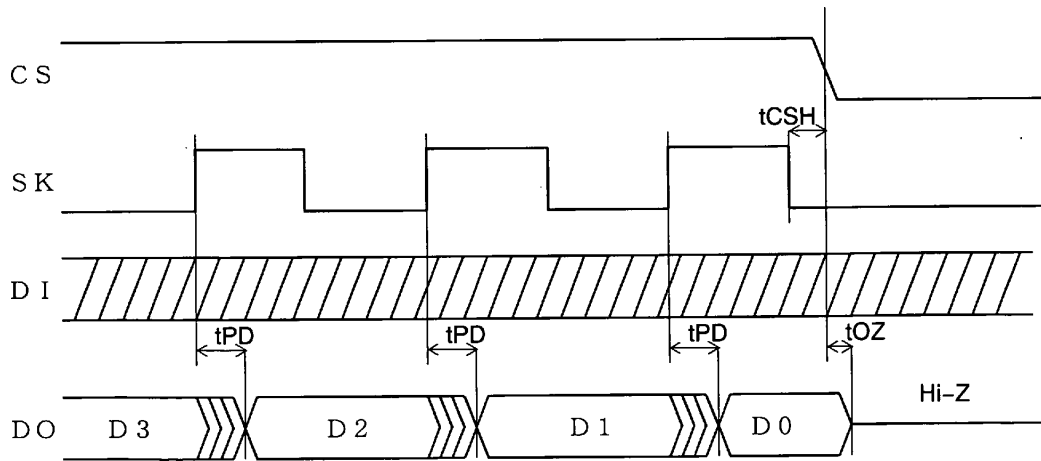

The End of Instruction

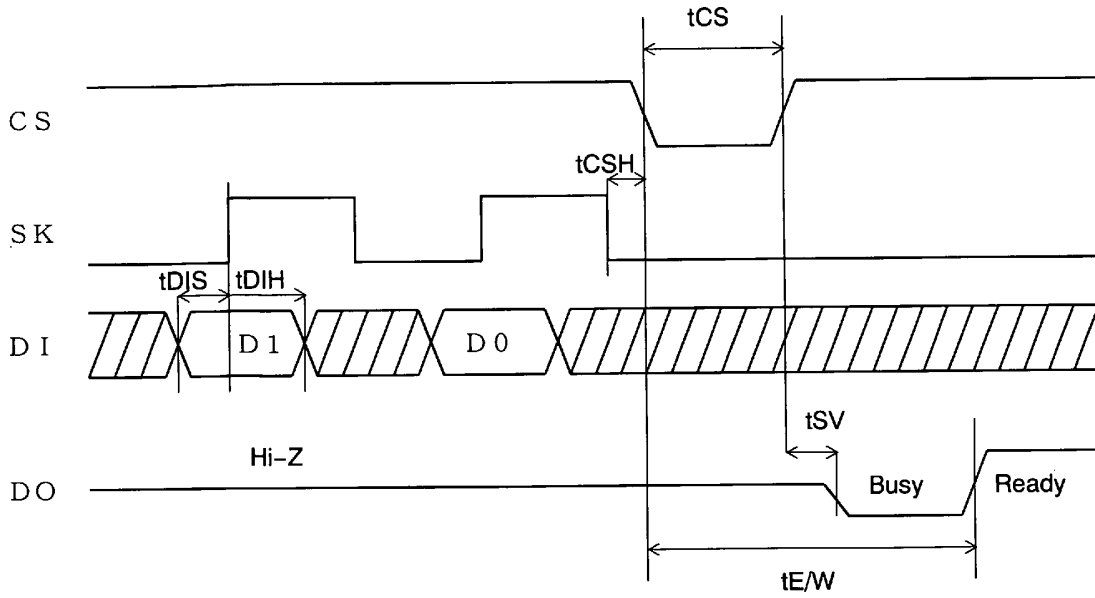

$\overline{\text{Busy/Ready}}$ Signal Output (AK93C85A)

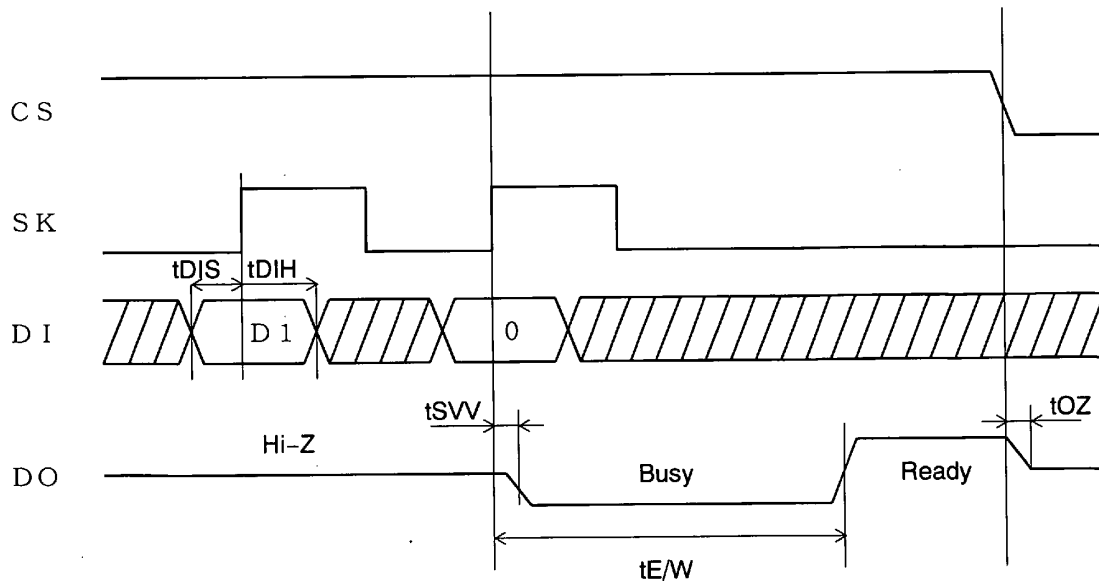

$\overline{\text{Busy/Ready}}$ Signal Output (AK93C95A/10A)

IMPORTANT NOTICE

- These products and their specifications are subject to change without notice. Before considering any use or application, consult the Asahi Kasei Microsystems Co., Ltd. (AKM) sales office or authorized distributor concerning their current status.
- AKM assumes no liability for infringement of any patent, intellectual property, or other right in the application or use of any information contained herein.
- Any export of these products, or devices or systems containing them, may require an export license or other official approval under the law and regulations of the country of export pertaining to customs and tariffs, currency exchange, or strategic materials.
- AKM products are neither intended nor authorized for use as critical components in any safety, life support, or other hazard related device or system, and AKM assumes no responsibility relating to any such use, except with the express written consent of the Representative Director of AKM. As used here:
 - (a) A hazard related device or system is one designed or intended for life support or maintenance of safety or for applications in medicine, aerospace, nuclear energy, or other fields, in which its failure to function or perform may reasonably be expected to result in loss of life or in significant injury or damage to person or property.
 - (b) A critical component is one whose failure to function or perform may reasonably be expected to result, whether directly or indirectly, in the loss of the safety or effectiveness of the device or system containing it, and which must therefore meet very high standards of performance and reliability.
- It is the responsibility of the buyer or distributor of an AKM product who distributes, disposes of, or otherwise places the product with a third party to notify that party in advance of the above content and conditions, and the buyer or distributor agrees to assume any and all responsibility and liability for and hold AKM harmless from any and all claims arising from the use of said product in the absence of such notification.