

**Circuits from the Lab®**  
Reference Designs

Circuits from the Lab® reference designs are engineered and tested for quick and easy system integration to help solve today's analog, mixed-signal, and RF design challenges. For more information and/or support, visit [www.analog.com/CN0355](http://www.analog.com/CN0355)

### Devices Connected/Referenced

AD7793	3-Channel, Low Noise, Low Power, 24-Bit, Sigma-Delta ADC
AD8420	Wide Supply Range, Micropower, Rail-to-Rail In-Amp
ADA4096-2	30 V, MicroPower, Overvoltage Protection, Rail-to-Rail Input/Output (RRIO), Dual Op Amp

## Low Power, Temperature Compensated Bridge Signal Conditioner and Driver

### EVALUATION AND DESIGN SUPPORT

#### Circuit Evaluation Boards

- [CN-0355 Evaluation Board \(EVAL-CN0355-PMDZ\)](#)
- [System Demonstration Platform \(EVAL-SDP-CB1Z\)](#)
- [SDP to PMOD Interposer Board \(SDP-PMD-IB1Z\)](#)

#### Design and Integration Files

- [Schematics, Layout Files, Bill of Materials](#)

### CIRCUIT FUNCTION AND BENEFITS

The circuit in Figure 1 is a complete, low power signal conditioner for a bridge type sensor and includes a temperature compensation channel. This circuit is ideal for a variety of industrial pressure sensors and load cells that operate with drive voltages of between 5 V and 15 V.

The circuit can process full-scale signals from approximately 10 mV to 1 V, using the internal programmable gain amplifier (PGA) of the 24-bit, sigma-delta ( $\Sigma$ - $\Delta$ ) ADC, making it suitable for a wide variety of pressure sensors.

The entire circuit uses only three ICs and requires only 1 mA (excluding the bridge current). A ratiometric technique ensures that the accuracy and stability of the system does not depend on a voltage reference.

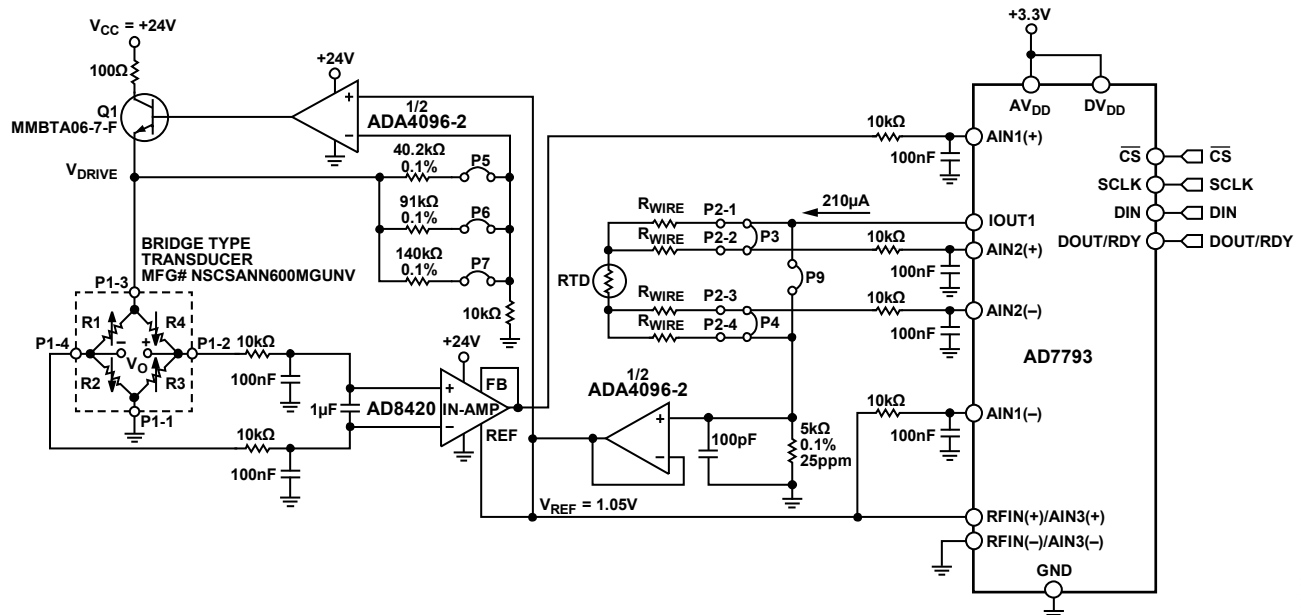

Figure 1. Differential Bridge Type Transducer Monitor with Temperature Compensation (Simplified Schematic: all Connections and Decoupling not Shown)

#### Rev. 0

Circuits from the Lab® reference designs from Analog Devices have been designed and built by Analog Devices engineers. Standard engineering practices have been employed in the design and construction of each circuit, and their function and performance have been tested and verified in a lab environment at room temperature. However, you are solely responsible for testing the circuit and determining its suitability and applicability for your use and application. Accordingly, in no event shall Analog Devices be liable for direct, indirect, special, incidental, consequential or punitive damages due to any cause whatsoever connected to the use of any Circuits from the Lab circuits. (Continued on last page)

**CIRCUIT DESCRIPTION**

The circuit shown in Figure 1 is based on the [AD7793](#), 24-bit,  $\Sigma$ - $\Delta$ . It has three differential analog inputs and has an on-chip, low noise PGA with gain that ranges from unity gain to 128, making it ideal for multiple sensor interfaces. The [AD7793](#) consumes a maximum of only 500  $\mu$ A and is therefore suitable for low power applications. It has a low noise, low drift internal band gap reference and can accept an external differential reference. The output data rate is software programmable from 4.17 Hz to 470 Hz.

The [AD8420](#) low power in-amp with a supply current of 80  $\mu$ A maximum, can operate up to 36 V single-supply and is used to remove the common voltage at the bridge transducer. It can also provide gain, if needed, to the small differential signal output of the transducer.

The [ADA4096-2](#), dual channel op amp, with a typical supply current of 60  $\mu$ A per amp and a wide operating input voltage range of up to 30 V, drives the sensor bridge. The other half of the [ADA4096-2](#) is used as a buffer for the reference voltage.

There are a wide variety of pressure sensors requiring a voltage drive between 5 V and 15 V. The circuit shown in Figure 1 provides a complete solution for bridge type transducers and has four critical sections; the transducer voltage drive, the in-amp, the reference buffer, and the ADC.

**Bridge Type Transducer Voltage Drive**

The [ADA4096-2](#) is configured as a noninverting amplifier with configurable gain set by the feedback resistor, as shown in Figure 2.

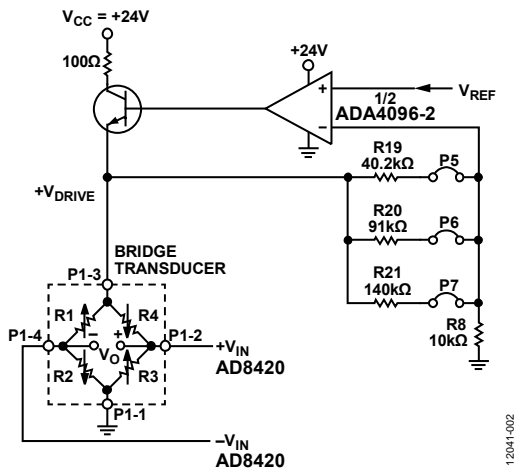

Figure 2. Transducer Voltage Drive

The gain is set by configuring the jumpers indicated in Table 1.

**Table 1. Pin Configuration for Specific Voltage Drive**

Gain	R19/R20/R21 R <sub>F</sub> Feedback	P5	P6	P7
5.02	40.2 k $\Omega$	Short	Open	Open
10.1	91 k $\Omega$	Open	Short	Open
15	140 k $\Omega$	Open	Open	Short

The transfer function can be computed as follows:

$$V_{DRIVE} = V_{REF} \left( 1 + \frac{R_F}{R8} \right)$$

where  $R_F$  can be 40.2 k $\Omega$ , 91 k $\Omega$ , or 140 k $\Omega$ , and  $R8 = 10$  k $\Omega$ .

An NPN transistor is used to boost the current needed to drive the bridge sensor. Feedback to the inverting input of the [ADA4096-2](#) makes the inverting input voltage equal to the noninverting input voltage, thereby ensuring a constant voltage of the voltage drive across the bridge circuit.

Transistor Q1 is a BJT that has maximum breakdown voltage of 80 V, capable of dissipating 0.35 W at 25°C. The maximum collector current is 500 mA.

**Instrumentation Amplifier**

The [AD8420](#) rejects the common-mode voltage generated at the bridge and only amplifies the differential bridge voltage, as shown in Figure 3. The [AD8420](#) has rail-to-rail output voltage swing that is completely independent of the input common-mode voltage. This feature exempts the [AD8420](#) from the restrictions caused by the interaction between the common-mode input and output voltages associated with most conventional instrumentation amplifier architectures. The gain of the in-amp is set at unity.

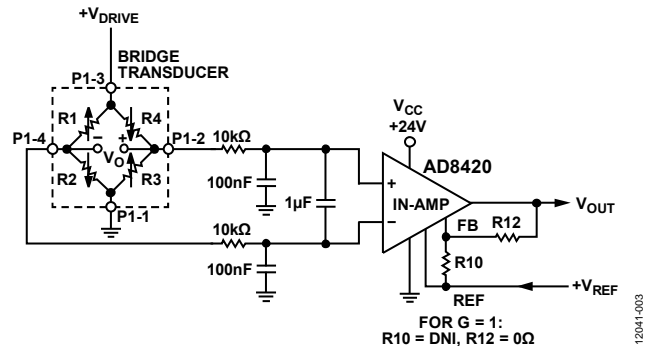

Figure 3. [AD8420](#) Instrumentation Amplifier

The input to the [AD8420](#) has a differential mode noise filter (20 k $\Omega$ /1  $\mu$ F/100 nF) with a 7.6 Hz bandwidth and a common-mode noise filter (10 k $\Omega$ /100 nF) with a 150 Hz bandwidth.

Traditional instrumentation amplifier architectures require the reference pin to be driven with a low impedance source. Any impedance at the reference pin degrades both common-mode rejection ratio (CMRR) and gain accuracy. With the [AD8420](#) architecture, resistance at the reference pin has no effect on CMRR. The transfer function of the [AD8420](#) is

$$V_{OUT} = G (V_{IN+} - V_{IN-}) + V_{REF}$$

where:

$$V_{REF} = 1.05 \text{ V}$$

$$G = 1 + (R12/R10)$$

The [AD8420](#) differential input voltage is internally limited with diodes at  $\pm 1$  V from  $-40^\circ\text{C}$  to  $+85^\circ\text{C}$ . If the input voltage exceeds the limit, the internal diodes start to conduct and draw current. The current is limited internally to a value that is safe for the [AD8420](#).

**Reference Buffer**

An excitation current of 210  $\mu$ A, generated by the AD7793, passes through the 5 k $\Omega$  resistor, as shown in Figure 4. This generates the 1.05 V reference voltage that is buffered by the ADA4096-2. The output of the buffer drives the reference of the AD7793 and the AD8420. The circuit is ratiometric; therefore, the error due to the variation in the voltage across the 5 k $\Omega$  resistor, caused by the 5% tolerance on the 210  $\mu$ A excitation current from the AD7793, is minimized. The buffered voltage reference also drives the amplifier that sets the voltage drive for the bridge transducer (see Figure 2).

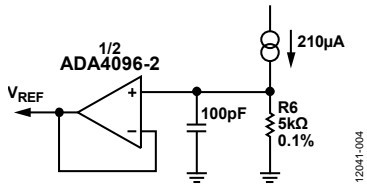

Figure 4. Voltage Reference Generator

**ADC Channel 1 Configuration: Bridge Type Sensor**

Channel 1 of the AD7793 measures the bridge sensor output from the AD8420. The external V<sub>REF</sub> (1.05 V) is used as a reference and therefore, the input range of the AD7793 is  $\pm$ 1.05 V centered on a common-mode voltage of +1.05 V.

**ADC Channel 2 Configuration: Temperature Sensor**

The second channel of the AD7793 monitors the voltage generated across a resistance temperature detector (RTD), driven by the 210  $\mu$ A excitation current, as shown in Figure 5.

Although 100  $\Omega$  platinum RTDs are popular, other resistances (200  $\Omega$ , 500  $\Omega$ , 1000  $\Omega$ , and so on) and materials (nickel, copper, nickel iron) can be specified. For this application, a 100  $\Omega$  DIN 43,760 Class A RTD is used.

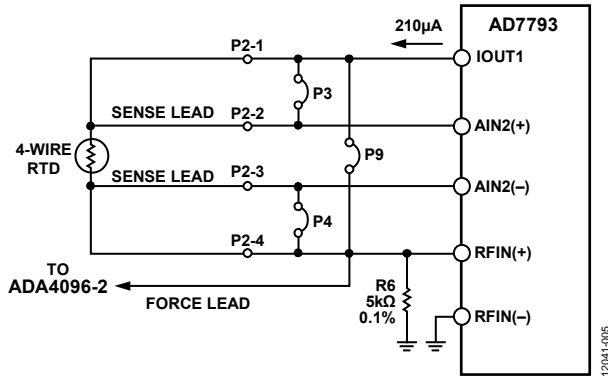

Figure 5. Use of Kelvin or 4-Wire Pt RTD Connections Provide High Accuracy

A 4-wire (Kelvin) connection, as shown in Figure 5, eliminates the effect of the RTD lead resistance. Note that 2-wire, 3-wire, and 4-wire configurations are also available using Link P3 and Link P4, as shown in Table 2.

**Table 2. Link Configuration for RTD Connections**

RTD Connection	P3	P4
2-Wire	Short	Short
3-Wire	Open	Short
4-Wire	Open	Open

Link P9 bypasses the RTD if temperature compensation is not required.

**Output Coding**

The output code for an input voltage on either channel is

$$Code = 2^{N-1} \left( \frac{AIN \times Gain}{V_{REF}} + 1 \right)$$

where:

$$AIN = AIN(+)-AIN(-) = AIN(+)-V_{REF}$$

Gain is the PGA gain setting, and N = 24.

**Voltage Supply Requirement**

For the circuit to operate properly, the supply voltage, V<sub>CC</sub>, must be greater than 6 V to provide a minimum 5 V drive for the bridge type transducer.

**System Calibration**

There are several methods for carrying out pressure sensor temperature calibration. For this application, a four-point calibration procedure was used. A good reference for the calibration procedure is AN13-01, *Active Temperature Compensation and Calibration for MEMS Pressure Sensors with Constant Voltage*, Silicon Microstructures, Inc., Milpitas, Ca.

**Test Data and Results**

**System Noise**

All data capture was taken using the CN-0355 Evaluation Software.

Two setup measurements were taken to capture the noise of the board. The first measurement, shown in Figure 6, was taken with the input to the AD8420 shorted, thereby measuring the peak-to-peak noise of the AD8420 and the AD7793. A sample of 1000 was taken; this resulted in a code spread of approximately 100 codes, which translates into a peak-to-peak noise of 12.5  $\mu$ V, or 17.36 noise free bits for a full-scale span of 2.1 V.

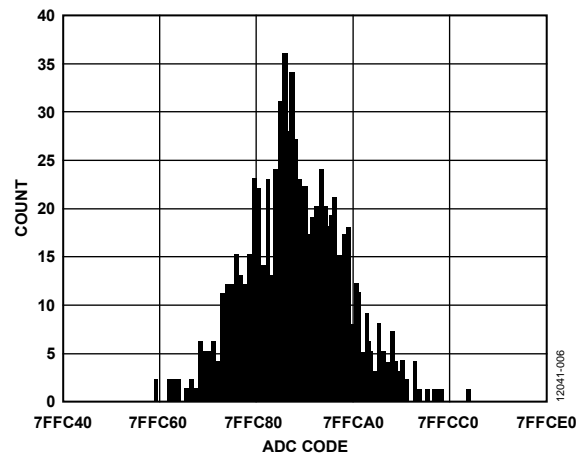

Figure 6. Histogram Showing Output Code Spread of 100 Codes with AD8420 Input Pins Shorted

The second measurement was made with a Honeywell N5CSANN600MGUNV gage pressure sensor connected to the evaluation board. This board mounted pressure sensor is unamplified and uncompensated, and the voltage driver was set at 10.1 V. This test effectively shows the noise contributed by the whole system, including the transducer noise, as shown in Figure 7. A sample of 1000 was taken; this resulted in a code spread of approximately 120 codes, which translates into a peak-to-peak noise of 15  $\mu$ V, or 17.1 noise free bits for a full-scale span of 2.1 V.

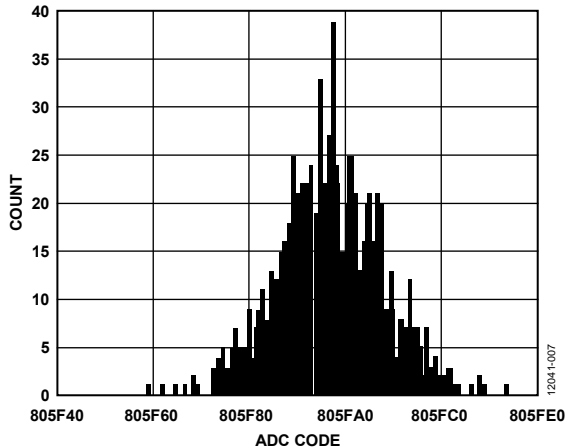

Figure 7. Histogram Showing Output Code Spread of 120 Codes with Pressure Sensor Connected

**System Current Consumption**

Table 3 shows the total current consumption of the system, excluding the current consumed by the pressure transducer.

**Table 3. Maximum Circuit Currents at 25°C**

Component	Consumptions (mA)
ADA4096-2	0.150
AD8420	0.080
AD7793	0.400
Excitation Current (R6)	0.210
R19 and R8 Current	0.104
Total	0.944

The Honeywell N5CSANN600MGUNV pressure sensor has an impedance of about 3 k $\Omega$ , which adds approximately 3.36 mA to the total current in Table 3.

The current consumed by the system can be further reduced by driving the RTD with a lower current, such as 10  $\mu$ A, and at the same time use a higher RTD resistance value, such as 1 k $\Omega$ .

**Error Analysis for Active Components**

The maximum and root-sum-square (RSS) errors, due to the active components in the system for AD8420 and the ADA4096-2, are shown in Table 4.

**Table 4. System Error Analysis for Full-Scale Range (FSR) = 1.05 V**

Error Component	Error	Error Value	Error % FSR
AD8420	Offset	250 $\mu$ V	0.025%
	Gain	0.05%	0.050%
ADA4096-2 (1/2, G = 10)	Offset	3 mV	0.300%
ADA4096-2 (1/2, G = 1)	Offset	300 $\mu$ V	0.030%
AD7793 (Internal Reference)	Offset	0.01%	0.010%
RSS Offset			0.060%
RSS Gain			0.050%
RSS FSR Error			0.110%
Maximum Offset			0.365%
Maximum Gain			0.050%
Maximum FSR Error			0.415%

**Total Circuit Accuracy**

A good approximation of the total error contributed by the resistor tolerances is to assume that each of the critical resistors contributes equally to the total error. The two critical resistors are R8 and any of the R19, R20, or R21 resistors. The worst case resistor tolerance build up of 0.1% yields a total resistor error of 0.2% maximum. If RSS errors are assumed, the total RSS error is  $0.1\sqrt{2} = 0.14\%$ .

Combining the resistor errors with the component errors from Table 4 yields the following results:

- Offset error = 0.365% + 0.1400% = 0.505%
- Gain error = 0.050% + 0.1400% = 0.190%
- Full-scale error = 0.415% + 0.1400% = 0.555%

These errors assume that calculated resistor values are selected, that the only errors are tolerance errors, and that the voltage drive for the transducer is set to a gain of 10.1.

The linearity error was tested over an input range of -500 mV to +500 mV, using the setup shown in Figure 10. The total nonlinearity was approximately 0.45%. The nonlinearity is primarily caused by the input transconductance (gm) stage of the AD8420.

The total output error (%FSR) is calculated by taking the difference between the measured output voltage and the ideal output voltage, dividing by the FSR of the output voltage, and multiplying the result by 100. The results of this calculation are shown in Figure 8.

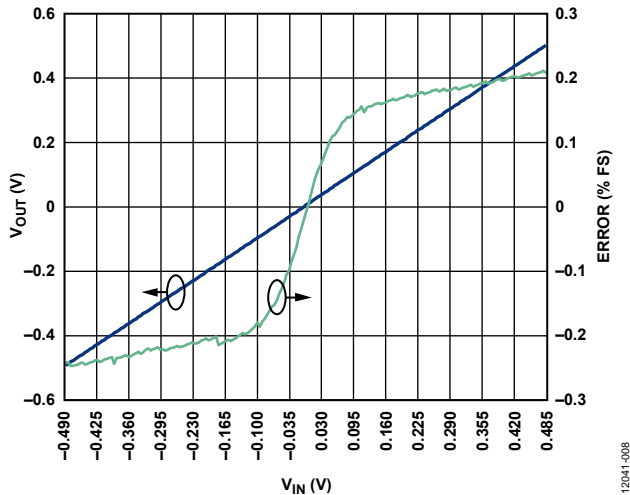

Figure 8. Bridge Transducer Simulated Output Voltage (with Associated Linearity Error Plot) vs. ADC Reading

Figure 9 shows a photo of the [EVAL-CN0355-PMDZ](#) evaluation board. Complete documentation for the system can be found in the [CN-0355 Design Support Package](#).



Figure 9. Photo of [EVAL-CN0355-PMDZ](#) Board

## COMMON VARIATIONS

Other suitable ADCs are the [AD7792](#) and the [AD7785](#). Both devices have the same set of features as the [AD7793](#). However, the [AD7792](#) is a 16-bit ADC, and the [AD7785](#) is a 20-bit ADC.

The [AD8237](#), a micropower, zero drift, true rail-to-rail instrumentation amplifier can also be used for low supply voltage versions of this circuit configuration.

The [AD8226](#) in-amp is another option, when better linearity is needed at a higher current consumption (approximately 525  $\mu$ A).

For a low supply voltage range application that requires a low noise and offset voltage, a dual channel [AD8606](#) is an alternative to the [ADA4096-2](#). The dual channel [AD8606](#) features very low offset voltage, low input voltage and current noise, and wide signal bandwidth. It uses the Analog Devices, Inc. patented DigiTrim<sup>®</sup> trimming technique, which achieves superior precision without laser trimming.

## CIRCUIT EVALUATION AND TEST

This circuit uses the [EVAL-CN0355-PMDZ](#) circuit board, the [EVAL-SDP-CB1Z](#) System Demonstration Platform (SDP) evaluation board, and the [SDP-PMD-IB1Z](#), which is a PMOD board base interposer for the SDP. The SDP and the [SDP-PMD-IB1Z](#)

boards have 120-pin mating connectors, allowing for the quick setup and evaluation of the performance of the circuit. To evaluate the [EVAL-CN0355-PMDZ](#) board using the [SDP-PMD-IB1Z](#) and the SDP, the [EVAL-CN0355-PMDZ](#) is connected to the [SDP-PMD-IB1Z](#) by a standard 100 mil spaced, 25 mil square, right angle, pin header connector.

## Equipment Required

The following equipment is needed to evaluate and test the [CN-0355](#) circuit:

- A PC with a USB port and Windows<sup>®</sup> XP and Windows<sup>®</sup> Vista (32-bit), or Windows<sup>®</sup> 7 (32-bit)
- The [EVAL-CN0355-PMDZ](#) circuit evaluation board
- The [EVAL-SDP-CB1Z](#) circuit evaluation board
- The [SDP-PMD-IB1Z](#) interposer board
- The [CN0355 Evaluation Software](#)
- A 6 V wall wart or alternate power supply
- The Yokogawa GS200 precision voltage source
- The Agilent E3631A voltage source

## Getting Started

Load the evaluation software by placing the [CN-0355 Evaluation Software](#) CD in the PC. Using **My Computer**, locate the drive that contains the evaluation software CD and open the **Readme** file. Follow the instructions contained in the **Readme** file for installing and using the evaluation software.

## Setup

The [CN-0355](#) evaluation kit includes self installing software on the a CD. This software is compatible with Windows XP (SP2) and Vista (32-bit and 64-bit). If the setup file does not run automatically, run the **setup.exe** file from the CD.

Install the evaluation software before connecting the evaluation board and SDP board to the USB port of the PC, to ensure that the evaluation system is correctly recognized when connected to the PC.

1. When installation from the CD is complete, power up the [SDP-PMD-IB1Z](#) evaluation board. Using the supplied cable, connect the SDP board (via Connector A) to the [SDP-PMD-IB1Z](#) evaluation board and then to the USB port of the PC that will be used for evaluation.
2. Connect the 12-pin, right angle, male pin header of the [EVAL-CN0355-PMDZ](#) to the 12-pin, right angle, female pin header of the [SDP-PMD-IB1Z](#).
3. Before running the program, connect the pressure sensor terminal and the RTD sensor to the terminal jacks of the [EVAL-CN0355-PMDZ](#).
4. When all the peripherals and power supply are connected and turned on, by clicking the **RUN** button on the GUI, and when the evaluation system is successfully detected by the PC, the [EVAL-CN0355-PMDZ](#) circuit board can then be evaluated using the evaluation software.

### Functional Block Diagram

The functional block diagram of the test setup is shown in Figure 10. The test setup must be connected as shown.

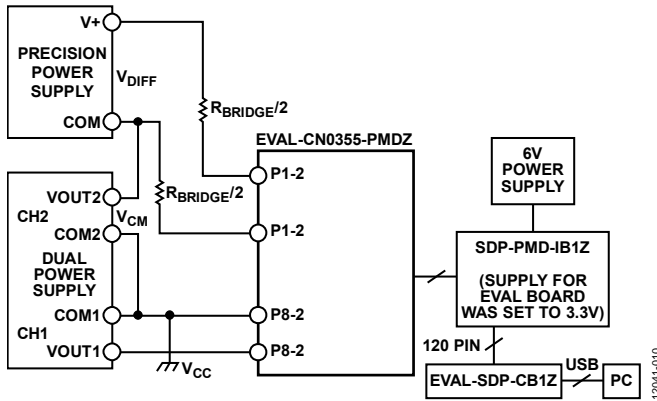

Figure 10. Test Setup Functional Block Diagram

The Agilent E3631A and the Yokogawa GS200 precision voltage supplies were used to power up the board and to simulate the sensor output. Channel CH1 of the Agilent E3631A was set at 24 V to serve as the  $V_{CC}$  power supply for the board and the other channel, CH2, was set at 5 V to generate the common-mode voltage. CH2 was connected in series with the Yokogawa GS200, as shown in Figure 7. The Yokogawa was connected to the input terminal of the evaluation board with a 1.5 k $\Omega$  series resistor that simulates the impedance of the bridge. The Yokogawa simulates the sensor output by generating  $\pm 500$  mV at a 25°C differential input voltage at the in-amp input.

The [CN-0355 Evaluation Software](#) was used to capture the data for linearity error shown in Figure 8 from the [EVAL-CN0355-PMDZ](#) evaluation board, using the setup shown in Figure 10.

Details of the software operation can be found in the [CN-0355 Software User Guide](#).

### LEARN MORE

[CN-0355 Design Support Package:](#)

[www.analog.com/CN0355-DesignSupport](http://www.analog.com/CN0355-DesignSupport)

[MT-004 Tutorial, \*The Good, the Bad, and the Ugly Aspects of ADC Input Noise—Is No Noise Good Noise?\*](#) Analog Devices.

[MT-022 Tutorial, \*ADC Architectures III: Sigma-Delta ADC Basics\*](#), Analog Devices.

[MT-023 Tutorial, \*ADC Architectures IV: Sigma-Delta ADC Advanced Concepts and Applications\*](#), Analog Devices.

[MT-031 Tutorial, \*Grounding Data Converters and Solving the Mystery of "AGND" and "DGND"\*](#), Analog Devices.

[MT-035 Tutorial, \*Op Amp Inputs, Outputs, Single-Supply, and Rail-to-Rail Issues\*](#). Analog Devices.

[MT-037 Tutorial, \*Op Amp Input Offset Voltage\*](#).

[MT-038 Tutorial, \*Op Amp Input Bias Current\*](#)

[MT-040 Tutorial, \*Op Amp Input Impedance\*](#)

[MT-051 Tutorial, \*Current Feedback Op Amp Noise Considerations\*](#)

[MT-065 Tutorial, \*In-Amp Noise\*](#)

[MT-066 Tutorial, \*In-Amp Bridge Circuit Error Budget Analysis\*](#)

[MT-101 Tutorial, \*Decoupling Techniques\*](#), Analog Devices

Kester, Walt. 1999. *Temperature Sensors*. Section 7. Analog Devices.

*Active Temperature Compensation and Calibration for MEMS Pressure Sensors with Constant Voltage*, Silicon Microstructures, Ins., Milpitas, Ca.

### Data Sheets and Evaluation Boards

[AD7793 Data Sheet](#)

[AD7793 Evaluation Board](#)

[ADA4096-2 Data Sheet](#)

[AD8420 Data Sheet](#)

### REVISION HISTORY

9/14—Revision 0: Initial Version

(Continued from first page) Circuits from the Lab reference designs are intended only for use with Analog Devices products and are the intellectual property of Analog Devices or its licensors. While you may use the Circuits from the Lab reference designs in the design of your product, no other license is granted by implication or otherwise under any patents or other intellectual property by application or use of the Circuits from the Lab reference designs. Information furnished by Analog Devices is believed to be accurate and reliable. However, Circuits from the Lab reference designs are supplied "as is" and without warranties of any kind, express, implied, or statutory including, but not limited to, any implied warranty of merchantability, noninfringement or fitness for a particular purpose and no responsibility is assumed by Analog Devices for their use, nor for any infringements of patents or other rights of third parties that may result from their use. Analog Devices reserves the right to change any Circuits from the Lab reference designs at any time without notice but is under no obligation to do so.